



ASC IMU 8 Tactical Grade Inertial Measurement Unit



SPECIFICATIONS

- 6 DOF System
- Modular Concept – Measurement Range Selection
- MEMS Capacitive and Vibrating Ring Technology
- Measurement Range Accelerometers: ± 2 to ± 30 g
- Measurement Range Gyroscopes: ± 10 to ± 400 °/s
- Aluminum Housing
- Made in Germany

ANALOG INERTIAL MEASUREMENT UNITS

ASC's analog inertial measurement units are based on three accelerometers and three gyroscopes that are integrated in a single housing. The modular concept allows to adapt all IMUs to the exact requirements of the application. Ideal measurement ranges for the accelerometers and gyroscopes are selectable and combinable. The ASC IMU 8 features outstanding bias stability and angular random walk leading to tactical grade performance. The low noise and excellent long-term stability ensure reliable measurement of position changes in all 6 degrees of freedom, with high repeatability. Differential analog signal output also gives users maximum data processing flexibility.

DESCRIPTION

The inertial measurement unit (IMU) is based on proven MEMS accelerometers and gyroscopes for detecting the smallest linear accelerations and angular rates. The integrated electronic circuitry enables separate analog voltage outputs for all 6 degrees of freedom and flexible power supply voltage from 8 to 30 VDC. The ASC IMU 8 features outstanding in-run bias stability (<45 μ g) of the integrated accelerometers. In addition, the gyroscopes providing FOG-like performance based on minimum angular random walk of <0.01 °/ $\sqrt{\text{hr}}$ and a bias stability of <0.1 °/hr.

The IMU feature a lightweight, reliable aluminum housing with protection class IP65 and a detachable connector cable with configurable length and connectors.

The ASC IMU 8 enables high-precision position measurements and bridging navigation in numerous areas of application, such as automated guided vehicles, ship guidance and control, robots, rail vehicles or aircraft systems.



FEATURES

- Tactical Grade IMU
- ITAR free
- Low Noise Differential Analog Voltage Output Signal
- Excellent long-term Bias and Scale Factor Stabilities
- Outstanding Bias Stability and Angular Random Walk
- High Shock and Vibration Resistance

OPTIONS

- Customized Cable Length
- Customized Connector
- Integrated Cable

APPLICATIONS

- Railway Engineering
- Mid-term Bridging Navigation
- Automated Guided Vehicles as well as UAVs and ROVs

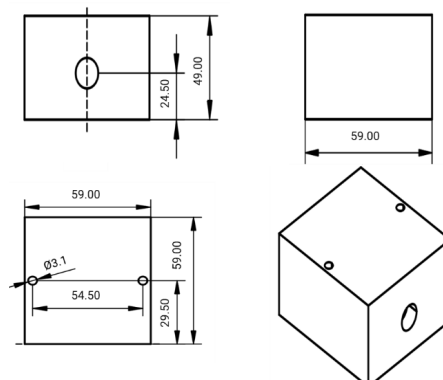



■ TYPICAL SPECIFICATION OF THE IMU

An inertial measurement unit (IMU) is a 6-DOF system that measures linear and angular motion using a combination of accelerometers and gyroscopes. The MEMS based IMUs feature a range of precision inertial sensors, including:

- 3 accelerometers (see detailed specification on page 3)
- 3 gyroscopes (see detailed specifications on page 4)

The IMU thus outputs acceleration and angular rate signals in the form of a differential analog voltage signal. Due to the excellent long-term stability and the low noise of the sensors used, it is possible to reliably obtain position changes in all 6 DOFs with high accuracy and repeatability.

Based on high-end specification of the ASC IMU 8, please note that an export license is required for the accelerometer's measurement ranges ± 2 g, ± 5 g and ± 10 g due to dual use category 7A101. Please contact us for further information.

Dynamic

Measurement Range (accelerometers)	g	± 2 to ± 30
Measurement Range (gyroscopes)	$^{\circ}/s$	± 10 to ± 400

Electrical

Power Supply Voltage	V	8 to 30
Operating Current Consumption	mA	<120
Isolation		Case Isolated

Temperature Sensor

Analog Output Voltage Signal at 25 °C	V	-0.83
Scale Factor	mV/K	-11.77 \pm 0.8

Environmental

Operating Temperature Range	$^{\circ}C$	- 40 to +85
Storage Temperature Range	$^{\circ}C$	- 40 to +100
Shock Limit (0.1 ms, half - sine)	g	1000
Protection Class		IP65

Physical

Case Material		Anodized Aluminum
Connector Sensor Housing		15 -pin Comtronic (female)
Connector at Cable End		Optional
Mounting		M3 Screws
Weight (without cable)	gram	260
Cable		36 gram per meter AWG 30 Polyurethane (PUR) Diameter 4.5 mm



■ DETAILED TYPICAL SPECIFICATION OF THE ACCELEROMETERS

The key components of the capacitive accelerometers are high-quality micro-electro-mechanical systems (MEMS) that feature excellent long-term stability and reliability. This technology enables the measurement of static (DC) and constant accelerations, which can be used to calculate the velocity and displacement of moving objects. Depending on the design of the spring-mass-damping system, however, it is also possible to detect dynamic (AC) accelerations with amplitudes up to ± 30 g and within a frequency response range higher than 200 Hz (± 3 dB). Other advantages of capacitive accelerometers are their outstanding temperature stability, excellent response behavior and achievable resolution.

Dynamic

Measurement Range	g	± 2	± 5	± 10	± 16	± 30
Scale Factor (sensitivity)	mV/g	1350	540	270	170	90
Noise Density	$\mu\text{g}/\sqrt{\text{Hz}}$	10	20	35	55	105
Frequency Response Range (± 5 %)	Hz	150				
Frequency Response Range (± 3 dB)	Hz	>200				
Amplitude Non-Linearity	% FSO	0.3				
Transverse Sensitivity	%	<1				
In-run Bias Stability	μg	3	7.5	15	25	45
Resolution	μg	10	20	35	55	105

Electrical

Full Scale Output (differential mode)	V	± 2.7				
Positive (signal +), Analog Output Voltage Signal Range	V	0.3 to 3.0				
Negative (signal -), Analog Output Voltage Signal Range	V	0.3 to 3.0				
Offset (bias)	mV	± 10				
Broadband Noise (over specified frequency range ± 5 %)	μV	165	135	115	115	110
Resistive Load	k Ω	1000				

Environmental

Temperature Coefficient of the Scale Factor (typ)	ppm/K	120				
Temperature Coefficient of the Scale Factor (max)	ppm/K	20 to 220				
Temperature Coefficient of the Offset (max)	mg/K	± 0.1	± 0.2	± 0.4	± 0.6	± 1.2
Long-term Scale Factor Repeatability	ppm	400				
Long-term Bias Repeatability	mg	0.25	0.6	1.2	1.9	3.6

Physical

Sensing Element	MEMS Capacitive					
-----------------	-----------------	--	--	--	--	--



■ DETAILED TYPICAL SPECIFICATION OF THE GYROSCOPES

The key components of the tactical grade gyroscopes are high-quality micro-electro-mechanical systems (MEMS) that feature excellent long-term stability and reliability. The design of the micro-mechanical silicon structures makes the gyroscopes extremely insensitive to external impacts and vibrations. They are therefore ideal suited for use in harsh environmental conditions. Due to their very high performance, the gyroscopes fulfill the requirements of tactical grade applications with respect to the maximum achievable precision, which otherwise can be achieved only with fiber optic gyroscopes (FOG).

Dynamic

Measurement Range	°/s	±10	±25	±100	±200	±400
Scale Factor (sensitivity)	mV/°/s	200	80	20	10	5
Rate Noise Density	°/s/√Hz	0.007	0.007	0.012	0.012	0.012
Bandwidth	Hz	50	50	100	100	100
Amplitude Non-Linearity	% FSO	0.02 (typ) 0.05 (max)				
Bias Stability	°/hr	0.03	0.04	0.04	0.05	0.10
Angular Random Walk	°/√hr	0.005	0.006	0.006	0.008	0.010

Electrical

Full Scale Output (quasi - differential mode)	V	±2				
Positive, Analog Output Voltage Signal Range	V	0.4 to 4.4				
Reference Analog Output Voltage Signal	V	2.4				
Offset (bias) referred to Reference Output Voltage	mV	±10				

Environmental

Scale Factor Error over Temperature Range (typ)	%	±0.15	±0.15	±0.30	±0.30	±0.30
Scale Factor Error over Temperature Range (max)	%	±0.5				
Offset (bias) Error over Temperature Range (typ)	°/s	±0.10	±0.10	±0.15	±0.15	±0.15
Offset (bias) Error over Temperature Range (max)	°/s	±0.20	±0.20	±0.25	±0.25	±0.25
Vibration induced Noise	°/s/g ²	0.01				
Vibration Rectification Error	°/s/g ²	0.002				
g- Sensitivity	°/s/g	0.02				

Physical

Sensing Element	MEMS Vibrating Ring					
-----------------	---------------------	--	--	--	--	--



SENSOR CALIBRATION – ACCELEROMETERS

Factory Calibration (supplied with the sensor)

Part Number						
Measurement Range (sensor)	g	±2	±5	±10	±16	±30
Applied Frequency (min)	Hz	1	1	1	1	1
Applied Frequency (max)	Hz	100	100	100	100	100
Input Amplitude	m/s ²	5	5	5	5	5
Reference Frequency for Determination of Scale Factor	Hz	16	16	16	16	16

Calibration according DIN ISO 17025 (order separately)

Part Number						
Measurement Range (sensor)	g	±2	±5	±10	±16	±30
Applied Frequency (min)	Hz	0.5	0.5	0.5	0.5	0.5
Applied Frequency (max)	Hz	150	150	150	150	150
Input Amplitude	m/s ²	5	5	5	5	5
Reference Frequency for Determination of Scale Factor	Hz	16	16	16	16	16

The conversion factor 1g corresponds to 9.80665 m/s². If any other calibration procedure is required, don't hesitate to contact us. Furthermore, sensors have to be calibrated regularly to ensure accurate and precise results. Our services include both factory calibration and calibration in accordance with DAkkS guidelines. On request we will be glad to remind you of the next scheduled calibration of your sensors.

SENSOR CALIBRATION – GYROSCOPES

Factory Calibration (supplied with the sensor)

Part Number						
Measurement Range (sensor)	°/s	10	25	100	200	400
Applied Frequency (min)	Hz	1	1	1	1	1
Applied Frequency (max)	Hz	50	50	100	100	100
Input Amplitude	°/s	5	12.5	50	100	200
Reference Frequency for Determination of Scale Factor	Hz	16	16	16	16	16

Calibration according DIN ISO 17025 (order separately)

Part Number						
Measurement Range (sensor)	°/s	10	25	100	200	400
Applied Frequency (min)	Hz	1	1	1	1	1
Applied Frequency (max)	Hz	50	50	100	100	100
Input Amplitude	°/s	5	12.5	50	100	200
Reference Frequency for Determination of Scale Factor	Hz	16	16	16	16	16



CABLE CODE / PIN CONFIGURATION (15 WIRE SYSTEM) INCLUDING COMMON POWER SUPPLY FOR ALL AXES

15-Pin Sensor Connector (female)	Color Code ASC AK - IMU 8	Description
1 Supply +	Red	Power: supply voltage + 8 to +30 VDC
2 Supply -	Black	Power: GND
3 Acc Signal +	Green/Violet	X- Axis: positive, analog output voltage signal for differential mode
4 Acc Signal -	White/Violet	X- Axis: negative, analog output voltage signal for differential mode
5 Acc Signal +	Green/Grey	Y- Axis: positive, analog output voltage signal for differential mode
6 Acc Signal -	White/Grey	Y- Axis: negative, analog output voltage signal for differential mode
7 Acc Signal +	Green	Z- Axis: positive, analog output voltage signal for differential mode
8 Acc Signal -	White	Z- Axis: negative, analog output voltage signal for differential mode
9 Gyro Signal +	Yellow/Violet	X- Axis: positive, analog output voltage signal for quasi-differential mode
10 Gyro Signal -	Brown/Violet	X- Axis: reference analog output voltage signal for quasi-differential mode
11 Gyro Signal +	Yellow/Grey	Y- Axis: positive, analog output voltage signal for quasi-differential mode
12 Gyro Signal -	Brown/Grey	Y- Axis: reference analog output voltage signal for quasi-differential mode
13 Gyro Signal +	Yellow	Z- Axis: positive, analog output voltage signal for quasi-differential mode
14 Gyro Signal -	Brown	Z- Axis: reference analog output voltage signal for quasi-differential mode
15 Temperature	Red/Violet	Temp: analog output voltage temperature sensor

ORDERING INFORMATION

Series	Range Accelerometer [g]	Range Gyroscope [°/s]
ASC IMU 8	002	010
	005	025
	010	100
	016	200
	030	400

Example:

ASC IMU 8.002.010

Ordering information are based on standard configurations. All customized versions will lead to a change or extension of the corresponding product match code.

All types of ASC IMU 8 are fabricated for operating with a detachable connector cable which is part of the product but needs to be ordered separately. For connecting the sensor housing, a 15-pin Comtronic connector (male) is used and already assembled. Furthermore, the cable features different options like configurable length, integrating a cable switch or connectors at the cable end including customized pin configuration.

Based on high-end specification of the ASC IMU 8, please note that an export license is required for the accelerometer's measurement ranges ± 2 g, ± 5 g and ± 10 g due to dual use category 7A101. Please contact us for further information.



■ SAFETY PRECAUTION FOR INSTALLING AND OPERATING

This data sheet is a part of the product. Read the data sheet carefully before using the product and keep it available for future operation. Handling, electrical connections, mounting or any other work performed at the sensor must be carried out by authorized experts only. Appropriate safety precautions must be taken to exclude any risk of personal injury and damage to operating equipment as a result of a sensor malfunction.

Handling

The sensor is packaged in a reliable housing to protect the sensing elements and integrated electronic components from the ambient environment. However, poor handling of the product can lead to damages that may not be visible and cause electrical failure or reliability issues. Handle the component with caution:

- Avoid shocks and impacts on the housing, such as dropping the sensor on hard surface
- Never move the sensor by pulling the cable
- Make sure that the sensor is used within the specified environmental conditions
- Transport and store the sensor in its original or similar packaging
- The sensor should be mounted on a stable flat surface with all screws tightened or other mounting options
- Avoid any deformation during mounting the sensor
- Mounting tolerances may have an influence on the measured result

Electrical

ASC's inertial sensors are working with many established data acquisition systems. However, make sure that a proper DAQ is used, for the corresponding operation principle of the sensor. Furthermore, suitable precautions shall be employed during all phases of shipment, handling and operating:

- Active sensor pins are susceptible to damage due to electrostatic discharge (ESD)
- Make sure that the sensor is used within the specified electrical conditions
- Check all electrical connections prior to initial setup of the sensor
- Completely shield the sensor and connecting cable
- Do not perform any electrical modifications at the sensor
- Do not perform any adaptations on the wiring or connectors while the device under power
- Never plug or unplug the electrical connection while the sensor is under power
- When a certain pin is not used during operation, make sure that the pin is insulated

Quality

- We have a quality management system according to ISO 9001:2015.
- The Deutsche Akkreditierungsstelle GmbH (DAkkS) has awarded to our calibration laboratory the DIN EN ISO/IEC 17025:2018 accreditation for calibrations and has confirmed our competence to perform calibrations in the field of mechanical acceleration measurements. The pictured DAkkS-ILAC logo refers exclusively to the accredited service.
- All ASC products are  - compliant.

