

g ASC 3511LN
MEMS Capacitive Accelerometer



SPECIFICATIONS

- Uniaxial
- MEMS Capacitive
- Measurement Range: ± 2 to ± 400 g
- Noise Density: 7 to $400 \mu\text{g}/\sqrt{\text{Hz}}$
- Frequency Range ($\pm 5\%$): DC to 2000 Hz
- Aluminum Housing
- Made in Germany

MEMS CAPACITIVE ACCELEROMETER

The key components in capacitive accelerometers are high-quality micro-electromechanical systems (MEMS) that feature excellent long-term stability and reliability. This technology enables the measurement of static (DC) and constant accelerations, which can be used to calculate the velocity and displacement of moving objects. Depending on the design of the spring-mass-damping system, however, it is also possible to detect dynamic (AC) accelerations with amplitudes up to ± 400 g and within a frequency response range of up to 2 kHz ($\pm 5\%$) or 4.2 kHz (± 3 dB). Other advantages of capacitive accelerometers are their outstanding temperature stability, excellent response behavior and achievable resolution.

DESCRIPTION

The accelerometers of type ASC 3511LN are based on proven MEMS technology and capacitive operating principle. The integrated electronic circuitry enables a differential analog voltage output (± 4 V FSO) and flexible power supply voltage from 6 to 40 VDC. The LN (Low Noise) accelerometers from ASC provide an outstanding noise performance from 7 to $400 \mu\text{g}/\sqrt{\text{Hz}}$ which is essential for demanding measurements of smallest frequencies and amplitudes.

The sensors feature a lightweight, reliable aluminum housing with protection class IP65 and an integrated cable with configurable length and connectors.

The compact design of uniaxial ASC 3511LN enables numerous possible applications, such as shock and vibration tests regarding operational stability of HV batteries.

FEATURES

- Very Low Noise Differential Voltage Output
- DC Response, Gas damped
- High Shock Resistance
- Excellent Offset and Scale Factor Stability

OPTIONS

- Customised Cable Length
- Customised Connector
- TEDS Module

APPLICATIONS

- Operational Stability Tests
- Test Bench Applications
- E-Mobility, HV Batteries

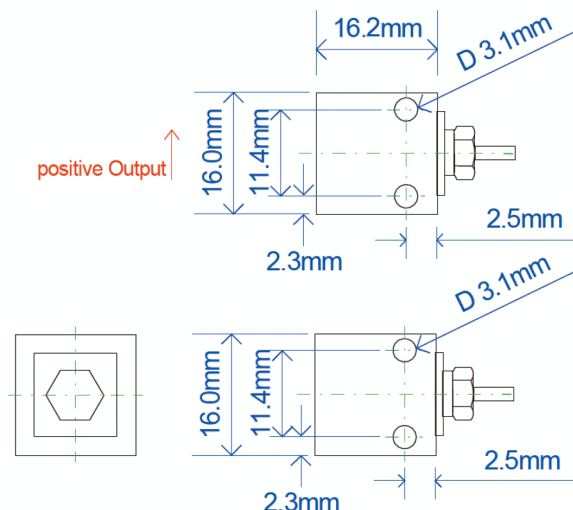



TYPICAL SPECIFICATIONS

Dynamic

Measurement Range	g	±2	±5	±10	±25	±50	±100	±200	±400
Scale Factor (sensitivity)	mV/g	2000	800	400	160	80	40	20	10
Noise Density	µg/√Hz	7	12	18	25	50	100	200	400
Specified Frequency Response Range (±5 %)	Hz	0 to 250	0 to 400	0 to 700	0 to 1300	0 to 1600	0 to 1700	0 to 1900	0 to 2000
Frequency Response Range (±3 dB)	Hz	0 to 525	0 to 800	0 to 1100	0 to 1750	0 to 2100	0 to 3000	0 to 3600	0 to 4200
Amplitude Non-Linearity	% FSO	<0.15 (typ) <0.5 (max)							
Transverse Sensitivity	%	<2 (typ) <3 (max)							

Electrical

Power Supply Voltage	V	6 to 40							
Operating Current Consumption	mA	<10							
Offset (bias)	mV	±80	±80	±40	±40	±40	±40	±40	±40
Broadband Noise (over specified frequency range ±5 %)	µV	225	195	190	145	160	165	175	180
Output Impedance	Ω	90							
Isolation		Case isolated							

Environmental

Temperature Coefficient of the Scale Factor (max)	ppm/K	±200							
Temperature Coefficient of the Offset (max)	mg/K	±0.8	±2	±4	±10	±20	±40	±80	±160
Operating Temperature Range	°C	-40 to +100							
Storage Temperature Range	°C	-40 to +100							
Shock Limit (max peak)	g	2000	2000	5000	5000	5000	5000	5000	5000
Protection Class		IP65							

Physical

Sensing Element		MEMS Capacitive							
Case Material		Anodized Aluminum							
Connector at Cable End		Optional							
Mounting		Adhesive Screw Holes							
Weight (without cable)	gram	3							
Cable		13 gram per meter AWG 30 Polyurethane (PUR) Diameter 3.1 mm							



■ SENSOR CALIBRATION

Factory Calibration (supplied with the sensor)

Part Number		#16722	#16724	#16726	#16728	#16730	#16732	#16734	#16736
Measurement Range (sensor)	g	±2	±5	±10	±25	±50	±100	±200	±400
Applied Frequency (min)	Hz	1	10	10	10	10	10	10	10
Applied Frequency (max)	Hz	100	400	700	1300	1600	1700	1900	2000
Input Amplitude	m/s ²	5	5	50	100	200	200	200	200
Reference Frequency for Determination of Scale Factor	Hz	16	80	80	80	80	80	80	80

Calibration according DIN ISO 17025 (order separately)

Part Number		#16738	#16740	#16742	#16744	#16746	#16748	#16750	#16752
Measurement Range (sensor)	g	±2	±5	±10	±25	±50	±100	±200	±400
Applied Frequency (min)	Hz	0.5	10	10	10	10	10	10	10
Applied Frequency (max)	Hz	150	800	1100	1750	2100	3000	3600	4200
Input Amplitude	m/s ²	5	5	50	100	200	200	200	200
Reference Frequency for Determination of Scale Factor	Hz	16	80	80	80	80	80	80	80

Remarks :

- The conversion factor 1 g corresponds to 9.80665 m/s².
- If any other calibration procedure is required, don't hesitate to contact us. Our services include both factory calibration and calibration in accordance with DAkkS guidelines.
- Furthermore, sensors have to be calibrated regularly to ensure accurate and precise results. On request we will be glad to remind you of the next scheduled calibration of your sensors.

■ CABLE CODE / PIN CONFIGURATION (4 WIRE SYSTEM)

Pin	Color Code	Description	
1	Supply +	Red	Power supply voltage +6 to +40 VDC
2	Supply -	Black	Power GND
3	Signal +	Green	Positive, analog output voltage signal for differential mode
4	Signal -	White	Negative, analog output voltage signal for differential mode



ORDERING INFORMATION

Series	Model	- Range [g]	- Cable Length [m]	Connector & Pinout
ASC 35	11LN	002	6	A
		005		
		010		
		025		
		050		
		100		
		200		
		400		

Example:

ASC 3511LN - 002-6A

Ordering information are based on standard configurations. All customized versions regarding connector and/or pinout will lead to a corresponding product match code :

- Standard length of the integrated cable is 6 meters. However, different customized cable lengths are possible on request.
- Standard version has no connector at the cable end which is identified by "A" in the product match code. However, it is possible to assemble almost all connector types during production.