

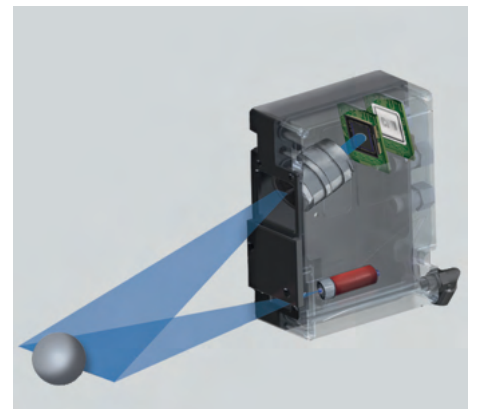

LASER POSITION SENSORS

Sensors, instruments & measurement systems for measuring distance, profiles & geometrical quantities

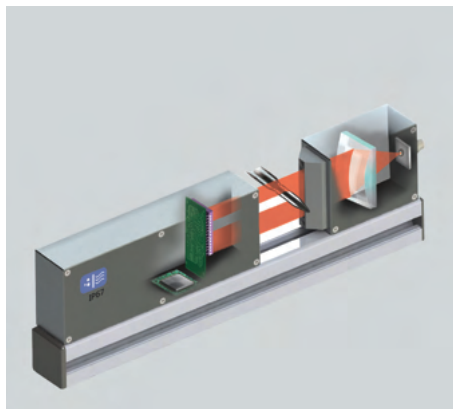
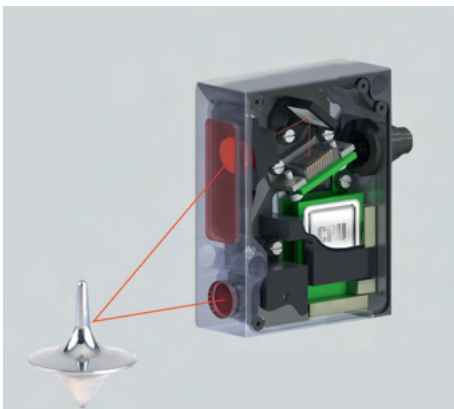

Your expert partner in sensors & controls

althensensors.com

ALTHEN
SENSORS & CONTROLS

INFORMATION ABOUT ALTHEN SENSORS & CONTROLS

Althen Sensors & Controls stands for pioneering measurement and sensor solutions. Since we are constantly looking to innovate we accept every measurement challenge, our engineers are only satisfied when the perfect solution for your measurement task is found. We develop customer-specific solutions in our in-house production facilities. Althen is partner of many recognized universities and leading organizations. We find ourselves in an intensive knowledge transfer, developing future technologies. Althen is one of the first companies in its branch with a certification by the German technical inspection association in Hessen (TÜV PROFICERT) in accordance with DIN EN ISO 9001:2015.



Our sensor solutions are divided into three main application areas: OEM, Test & Measurement and IIoT solutions.

Our in-house design and manufacturing capabilities allow us to develop customized sensor solutions and turn every measurement challenge into a sensor solution. In addition to our sensor solutions we offer complementary services such as: calibration, design & engineering, training and renting of measurement equipment. Your benefits of working with Althen: high quality sensor solutions, flexibility in developing a customized solution and fast prototyping.

Connecting the dots

Our main market is Western Europe and USA, with offices in Germany, the Netherlands, France, Sweden and the USA. With over 40 years of experience in sensor technology, Althen is your expert partner for sensor and measurement solutions.

For more information please visit our website www.althensensors.com



Althen Sensors & Controls is your specialised partner for sensors and measurement systems for OEM, Test & Measurement and Industrial IoT applications.

CONTENTS

Laser triangulation sensors	2
Laser inner diameter scanning probes.....	6
Absolute encoders	7
Optical micrometers	8
2D Laser scanners	10
Lamia software.....	12
3D Laser scanning systems	13
Inner diameter measurement systems.....	15
Special measurement systems.....	18
Railway measurement instruments	19
3D Wheel measurement system	23
Machine vision.....	24



LASER TRIANGULATION SENSORS

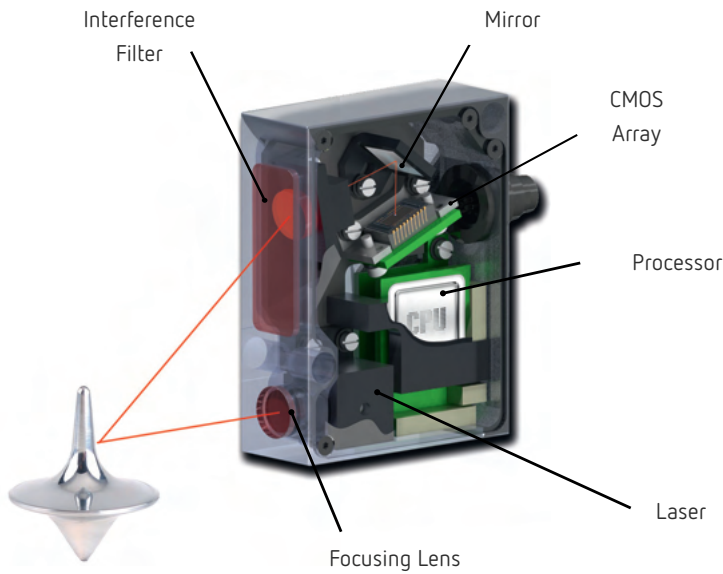

MAIN FEATURES

- Measuring ranges from 2 to 2500 mm
- ±1 µm accuracy
- Sampling rate up to 180 kHz
- RS232/RS485/Ethernet/CAN/ CANopen +4...20 mA/0...10V/ ModbusRTU
- Binocular sensors for laser scanning
- Binary and ASCII data formats
- Sensors with BLUE lasers to control high temperature, mirrored and semitransparent objects
- Sensors with IR lasers
- Mutual synchronization of the sensors (master-slave) for multi-axis measurement tasks
- Service Software for parameter setting and results visualization
- Free SDK and examples for Windows, Linux, .NET, MathLAB, LabView

ASSIGNMENT

Contactless dimensions, surface profile, deformation, vibration measurement, sorting, sensing presence or absence, positional checking, bulk materials and liquids level measurement.

OPERATION

Sensor operation is based on the principle of optical triangulation. Radiation of a semiconductor laser is focused by an objective on an object. The radiation scattered at the object is collected on the CMOS array by the input lens. Object motion causes a corresponding motion of the image. Built-in signal processor calculates the distance to the object according to the light spot image position on the CMOS array.

MODELS

- FDRF603- universal sensors
- FDRF603HS - high speed sensors
- FDRF600- long range sensors
- FDRF6001 - large-base sensors
- FDRF605 - compact sensors
- FDRF602 - super compact sensors
- FDRF607 - high-precision high-speed sensors
- FDRF609 - laser probes for inner surface control

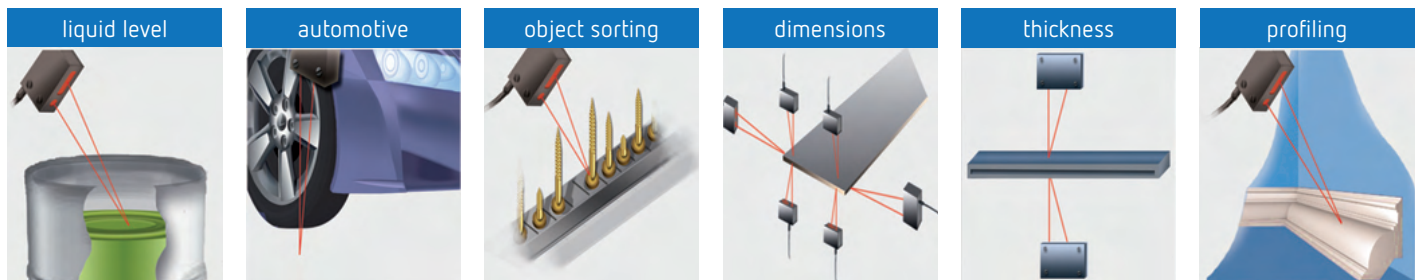

Parameter		Value
Output interface	digital	RS232 (max. 460,8 kbit/s) or RS485 (max. 921,6 kbit/s) or RS232 and CAN V2.0B (max 1Mbit/s) or Ethernet and (RS32 or RS485)
	analog	4...20 mA (≤500 Ω load) or 0...10 V
Synchronization input		2,4 – 5 V (CMOS, TTL)
Logic output		programmed functions, NPN: 100 mA max; 40 V max for output
Power supply, V		9 ...36
Power consumption, W		1,5..2
Environment resistance	Enclosure rating	IP67 (for the sensors with cable connector only)
	Vibration	20g/10...1000Hz, 6 hours, for each of XYZ axes
	Shock	30 g / 6 ms
	Operation temperature, °C	-10...+60, (-30...+60 for the sensors with in-built heater), (-30...+120 for the sensors with in-built heater and air cooling housing)
	Permissible ambient light, lx	10000 – FDRF603L, 30000 – FDRF603, >30000 – FDRF603P
	Relative humidity	5-95% (no condensation)
Storage temperature, °C	-20...+70	
Housing material		aluminum

LASER TRIANGULATION SENSORS

mm UNIVERSAL LASER SENSOR FDRF603 Series

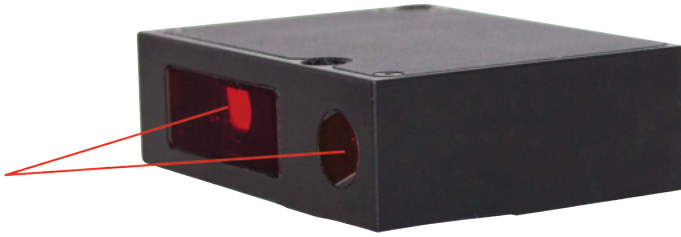

MAIN FEATURES

- Various diode powers
- Binocular sensors
- Available with Red, Blue or IR laser diodes
- Accuracy $\pm 0,05\%$ working range

OPTIONS

- Protective housing with air and water cooling
- Custom versions with non-standard base, range or housing shape
- Special version for use in high vibration conditions
- Special flexible cable for robotic applications
- Variants with round and elliptical spot

SOFTWARE

- Setting sensor parameters
- Receiving, storage, visualization
- Speed and acceleration calculation

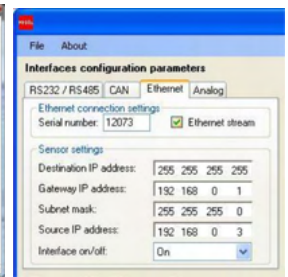
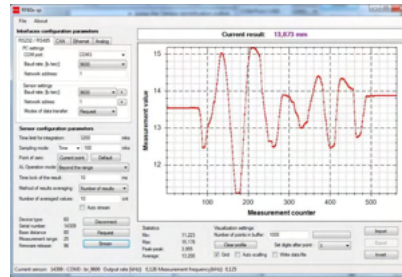
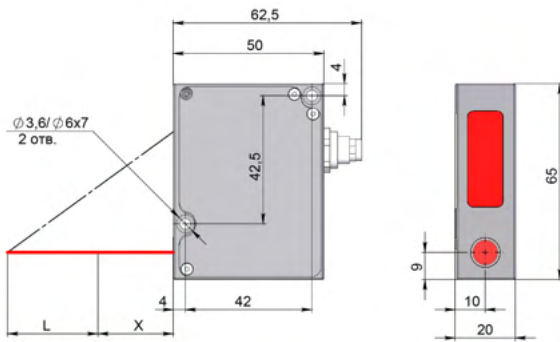

FDRF603-		R-X/4	X/2	X/5	X/10	X/15	X/25	X/30	X/50	X/100	X/250	X/500	X/750	X/1000	X/1250	
Base distance X, MM		39	15	15	15,25 60	15,30 65	25,45 80	35,55 95	45,65 105	60,90 140	80	125	145	245	260	
Measurement range, mm		4	2	5	10	15	25	30	50	100	250	500	750	1000	1250	
Linearity, %		± 0.05 of the range												± 0.1		
Resolution, %		0.01 of the range (for the digital output only)												0.02		
Temperature drift		0,02% of the range / °C														
Max. measurement frequency, Hz		9400														
Light source		red semiconductor laser, 660 nm wavelength or UV semiconductor laser 405 nm wavelength (BLUE version)														
Light source	model	FDRF603														
	output power	≤ 3 mW														
	laser safety Class	$\leq 0,2$	1													
	model	FDRF603L														
	output power	$\leq 0,95$ mW														
	laser safety Class	2 (IEC60825-1)														
Light source	model												FDRF603P			
	output power												≤ 20 mW			
	laser safety Class												3B (IEC60825-1)			
Weight (without cable)		100														

Note 1: FDRF603-R-39/4 sensor is designed to use with mirror surfaces and glass.

LASER TRIANGULATION SENSORS

mm HIGH SPEED LASER SENSOR FDRF603HS Series

MAIN FEATURES

- Universal high-speed compact laser sensors
- Sampling rate up to 180 kHz
- Available with Red and Blue laser diodes
- Ideal for fast event logging

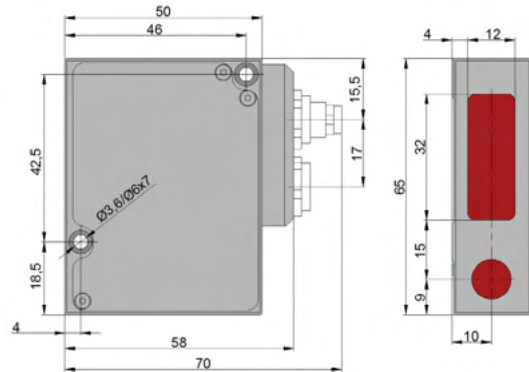

FDRF603HS-	X/2	X/5	X/10	X/15	X/25	X/30	X/50	X/100	X/250	X/500	X/750	X/1000	X/1250
Base distance X, mm	15	15	15, 25 60	15, 30 65	25, 45 80	35, 55 95	45, 65 105	60, 90 140	80	125	145	245	260
Measurement range, mm	2	5	10	15	25	30	50	100	250	500	750	1000	1250
Max. measurement frequency, kHz	60, 120, 180												
Linearity, % of the range	±0.1 (60 kHz), ±0.2 (120 kHz), ±0.3 (180 kHz)												
Resolution, % of the range	0.01 (60 kHz), 0.02 (120 kHz), 0.04 (180 kHz)												
Temperature drift	0,02% of the range/°C												
Light source	red semiconductor laser, 660 nm wavelength or UV semiconductor laser 405 nm wavelength (BLUE version)												
Output power	≤0,95 mW					≤4,8 mW					≤70 MBT		
Laser safety Class	3R (IEC60825-1)					3R (IEC60825-1)					3B (IEC60825-1)		
Weight (without cable)	110												

mm LARGE-BASE AND LONG RANGE SENSOR FDRF600 Series

MAIN FEATURES

- High-precision measurement of the position of remote objects
- High-speed (70 kHz) sensors

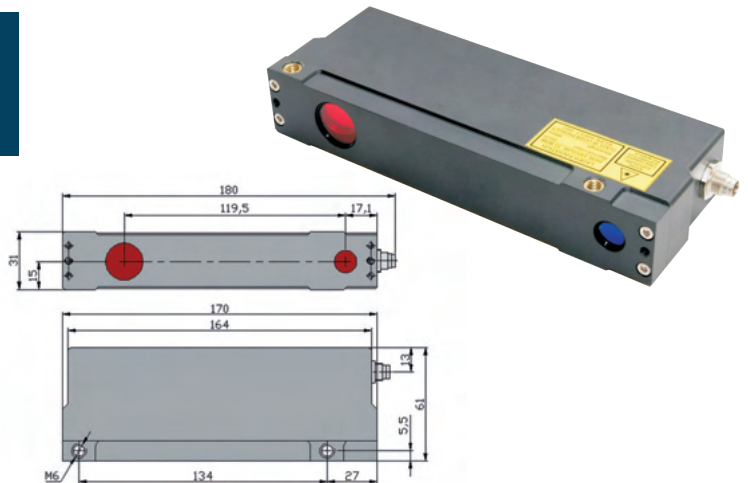

FDRF600-	X/10	X/30	X/40	X/100	X/250	X/500	X/600	X/1000	X/1000	X/1500	X/2000	X/2500	X/20	X/50
Base distance X, mm	230	300	330	500	230	300, 1000	230	1300	380	390	410	420	540	535
Measurement range, mm	10	30	40	100	250	500	600	1000	1000	1500	2000	2500	20	50
Max. measurement frequency	9,4 kHz, 70 kHz													
Linearity, % of the range	±0.1											±0.2		±0.05
Resolution, % of the range	0.01 of the range (digital output only)											0.03		0.01
Temperature drift	0,02% of the range/°C													
Light source	red semiconductor laser, 660 nm wavelength or UV semiconductor laser 405 nm wavelength (BLUE version)													
Output power	≤4,8 mW											≤20 mW		
Laser safety Class	3R (IEC60825-1)											3B (IEC60825-1)		
Weight (without cable)	500											2000		



LASER INNER DIAMETER SCANNING PROBES

Contactless measurement of inner diameter, ovality, coaxiality, cylindricity and shape of holes, tubes, hosepipes, bushes, gun barrels, etc.

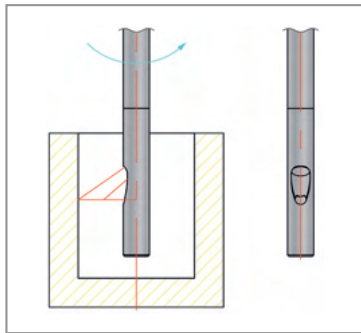

MAIN FEATURES

- Probe diameter – from 6 mm
- Measured inner diameter - from 6,5 mm
- Accuracy - from ± 2 μm
- Sampling rate - up to 9,4 kHz
- Probes with BLUE laser to control reflecting and semitransparent objects

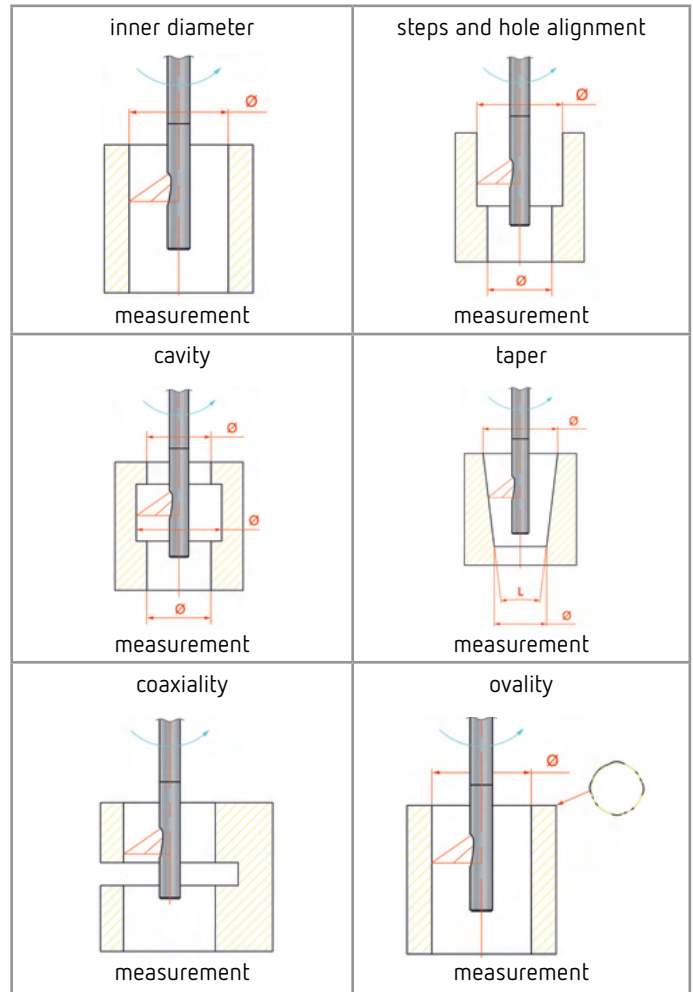

The probe is inserted into the hole and is driven in rotation. Laser triangulation sensor built in the probe measures the distance to the hole wall synchronously with the rotation angle of the probe. The set of the polar surface coordinates allows to calculate the required parameters.

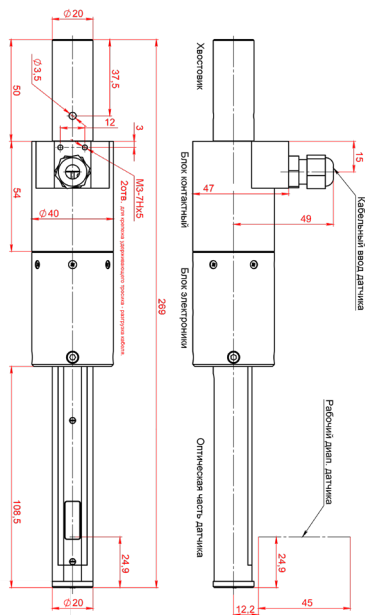

Diameter 20 mm | Range 45 mm

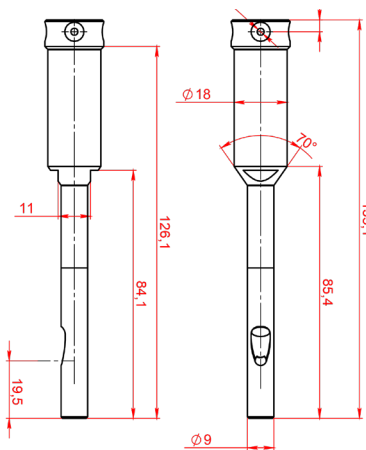

Diameter 9 mm | Range 5 mm

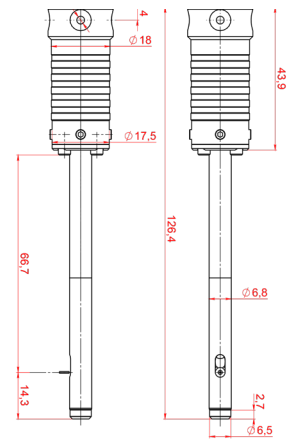

Diameter 6,5 mm | Range 3 mm

mm ABSOLUTE ENCODER FDRF25X Series

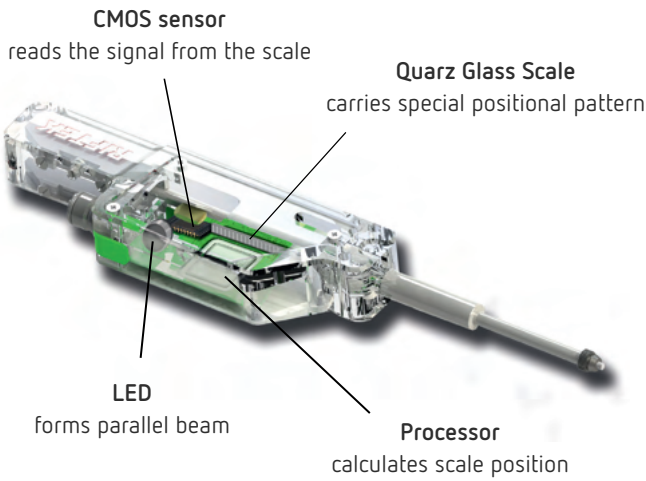

MAIN FEATURES

- Innovative technology of absolute measurement
- Measuring ranges from 3 to 55 mm
- 0.1 μm resolution
- Emulation of incremental encoder signals

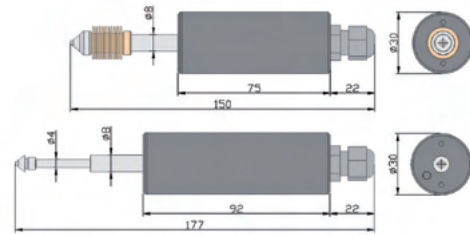

FDRF251

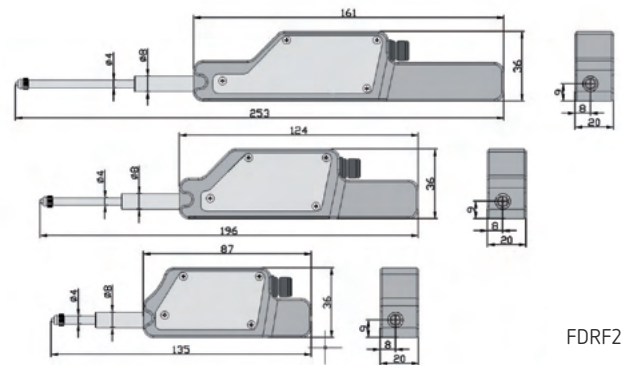

FDRF256



ASSIGNMENT

Absolute encoders are designed for measuring and checking displacements, dimensions, run-outs, surface profiles and deformations of engineered objects.

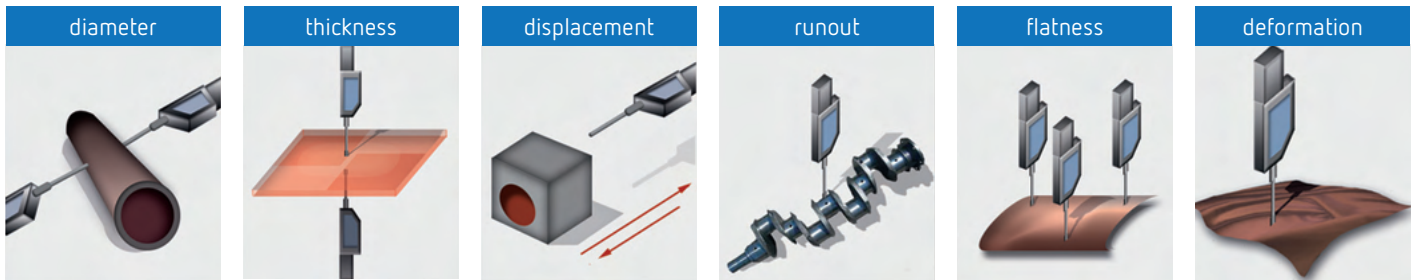

FDRF25X-		FDRF251-3	FDRF251-25	FDRF256-15	FDRF256-35	FDRF256-55
Measurement range, mm		3	25	15	35	55
Accuracy (at T=20 °C), μm			± 2			± 3
Resolution, μm				0.1 or 0.5 or 1 or 5 or 10		
Output interface	digital	RS422	(RS485 and SSI or RS232) and (EncD5 or EncD10 – emulation of quadrature signals of incremental trans-ducers)			
	analog	HET	0...20 mA (<500 Ohm load) or 0...10 V			
Synchronization input			HET		opto-isolated	
Logical outputs		HET	two outputs, NPN: 100 mA max; 40 V max			
Indication			HET	two-color LED (red/green)		
Power supply, V		12 (without analogue output) 15 (with analogue output)				
Power consumption, W		0,75				
Enclosure rating		IP57	IP50			
Operating temperature, °C		-40...+50	-10...+50			
Weight (without cable), gram		70	110	110	150	180

mm OPTICAL MICROMETER FDRF65X Series

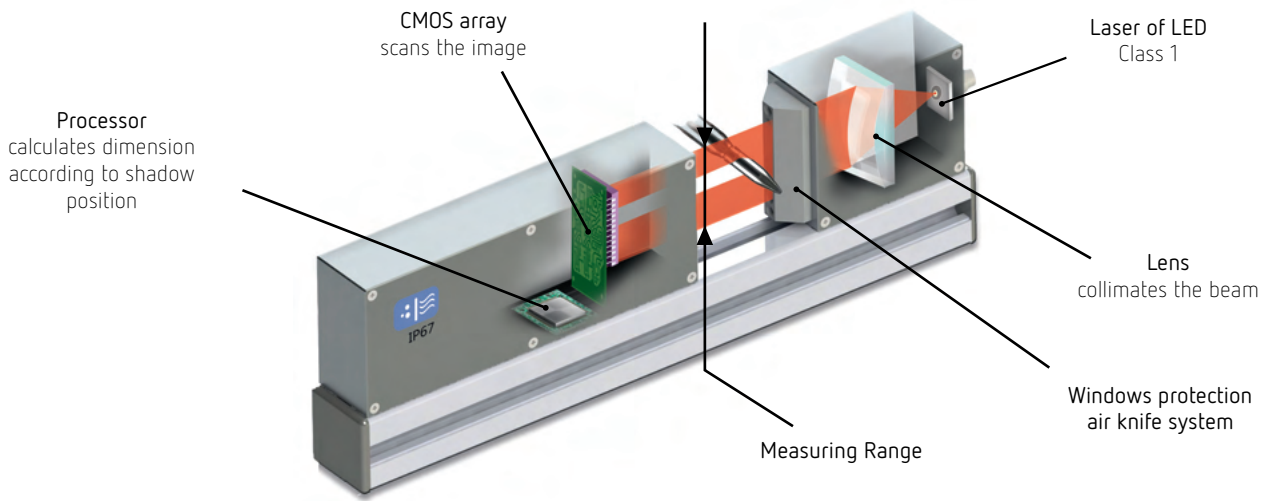

ASSIGNMENT

Contactless diameter, gaps and technological object position measurement.

WORKING PRINCIPLE

The micrometer operation is based on the so-called 'shadow' principle. The micrometer consists of two blocks – transmitter and receiver. Radiation of a semi-conductor laser or LED is collimated by a lens. With an object placed in the collimated beam region, shadow image formed is scanned with a photo-detector array. A processor calculates the position (size) of the object from the position of shadow border (/borders).



MAIN FEATURES

- Measurement range from 5 to 100 mm
- Up to $\pm 0.3 \mu\text{m}$ accuracy
- Up to 10,000 Hz sampling rate
- RS232/RS485/Ethernet/CAN +4...20 mA/0...10V
- Micrometers with telecentric lens
- Mutual synchronization of the sensors (master-slave) for multi-axis measurement tasks
- Service Software for micrometers parameterization
- Free SDK and examples for Windows, Linux, .NET, MathLAB, LabView
- Dual, three and multi axis Micrometers
- Air-knife window protection

MODELS

- FDRF651 - universal micrometers
- FDRF656 - high-precision micrometers with telecentric optics
- FDRF651XY and FDRF656XY - two-coordinate micrometers
- FDRF659 - edge sensors

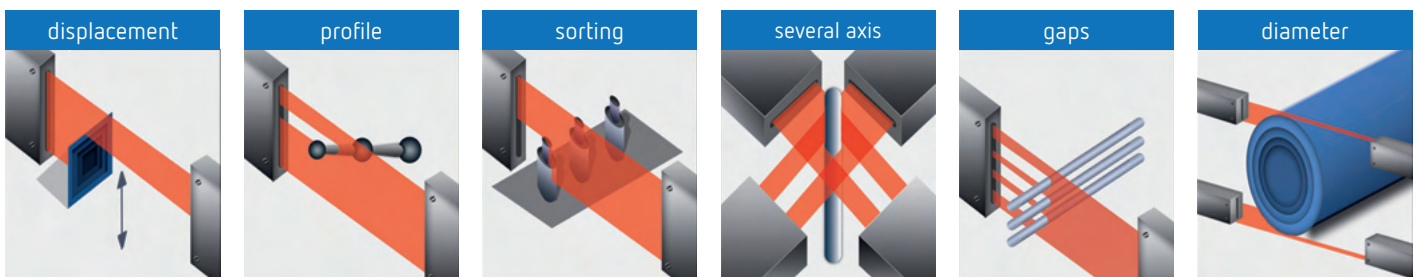

OPTICAL MICROMETERS

	A, mm	B, mm	C, mm	D, mm	E, mm	H, mm	H1, mm	K, mm	N, mm
FDRF651-25	51	139	62	25	13	28	42,5	30	30
FDRF651-50	91	120	134	50	20	31	45,5	40	80
FDRF651-75	128	132	132	75	15	31	45,5	40	80
FDRF651-100	165	165	150	98	20	31	45,5	40	80

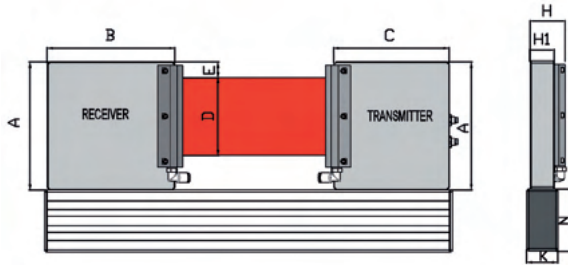

	A, mm	B, mm	C, mm	D, mm	E, mm	K, mm	R, mm	M, mm	N, mm
FDRF656-5	66	50	158	5	14	28	2	30	30
FDRF656-10	50	70	126	10	11,5	56	6	30	30
FDRF656-25	72	74	106	25	7	63	10	30	30
FDRF656-50	105	134	110	50	20	150	25	30	60
FDRF656-75	135	148	125	75	17	200	40	40	80
FDRF656-100	175	170	160	100	20	300	50	40	80

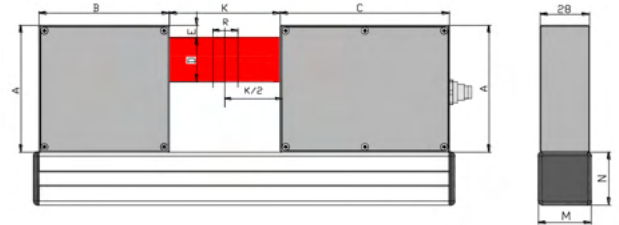

FDRF65X-	FDRF651-25	FDRF651-50	FDRF651-75	FDRF651-100	FDRF656-5	FDRF656-10	FDRF656-25	FDRF656-50	FDRF656-75	FDRF656-100
Measurement range, mm	25	50	75	98	±1X5	±3X10	±5X25	±7X50	±9X75	±10X100
Minimum size of the object, mm	0.5	1	1.5	2	0.03	0,05	0,1	0.1	0.2	0.3
Accuracy ¹ , um	±5	±10	±15	±20	±0,3	±0,5	±1	±1	±1	±1
Max measurement frequency, Hz	2000	2000	2000	2000	2000	10000	10000	1000	1000	1000
Light source	LED or laser									
Laser safety class	1 (IEC60825-1)									
Output interface	digital	RS232 (max. 921,6 kbit/s) or RS485 (max. 921,6 kbit/s) or Ethernet & (RS32 or RS485)								
	analog									
Synchronization input	2,4 – 5 B (CMOS, TTL)									
Logic output	three outputs, NPN: 100 mA max; 40 V max									
Power supply, V	24 (9 ...36)									
Power consumption, W	1,5.2									
Housing material	aluminum									
Weight (without cable), gram	600	2000	2600	4000	600	600	600	1500	3200	4500

¹ typical data obtained when a knife edge was used to interrupt the beam and distance between transmitter and receiver is equal of two measurement range

mm TWO AND TREE AXIS MICROMETER FDRF65X

Non-contact measurement of the diameter of wires, tubes, fibers, measurement of gaps and position.



mm EDGE SENSOR FDRF659 Series

The sensors are intended for non-contact measuring and monitoring the position of the edge (edges) of various objects, such as tapes, plates, substrates, etc.



mm 2D OPTICAL MICROMETER FDRF656.2D-60

Measurement of geometrical parameters of complex objects.

Parameter	Value
Distance between transmitter and receiver	30 mm
Measurement range	7 mm
Accuracy	±20 um

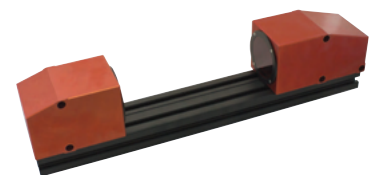
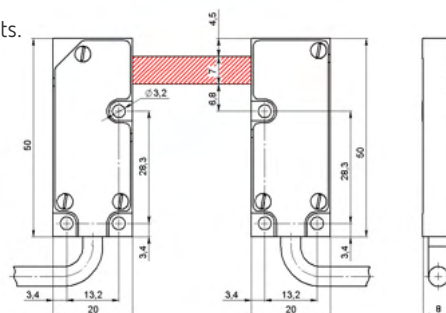

mm LASER SCANNER FDRF625 Series

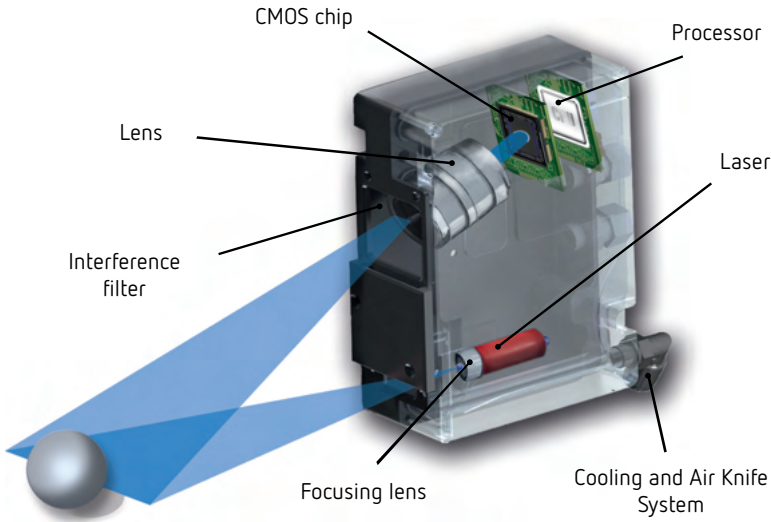

MAIN FEATURES

- Measuring ranges from 10 to 1500 mm
- $\pm 5 \mu\text{m}$ accuracy
- Sampling rate up to 2000 profiles/s
- RS232/RS485/Ethernet
- Binocular scanners for laser scanning
- Scanners with BLUE lasers to control high temperature, mirrored and semitransparent objects
- Scanners with high-power IR laser
- Mutual synchronization of the sensors (master-slave) for multi-axis measurement tasks
- Service Software for parameter setting and results visualization
- Free SDK and examples for Windows, Linux, .NET, MathLAB, LabView
- Specialized scanners for welding robots
- Specialized scanners for hole control

ASSIGNMENT

Non-contact measuring and checking of surface profile, dimensions, deformations, flatness, gaps, volume, 3D models construction.

WORKING PRINCIPLE

Scanner operation is based on the principle of optical triangulation. Radiation of a semiconductor laser is formed by a lens in a line and projected to an object. Radiation scattered from the object is collected by the lens and directed to a two-dimensional CMOS image sensor. The image of object outline thus formed is analyzed by a signal processor, which calculates the distance to the object (Z-coordinate) for each point of the set along the laser line on the object (X-coordinate). Scanners are characterized by base distance (beginning of the range), SMR, for Z-coordinate, measuring range (MR) for Z-coordinate, measuring range for X-coordinate at the beginning of Z (Xsmr) and measuring range for X-coordinate at the end of Z (Xemr).

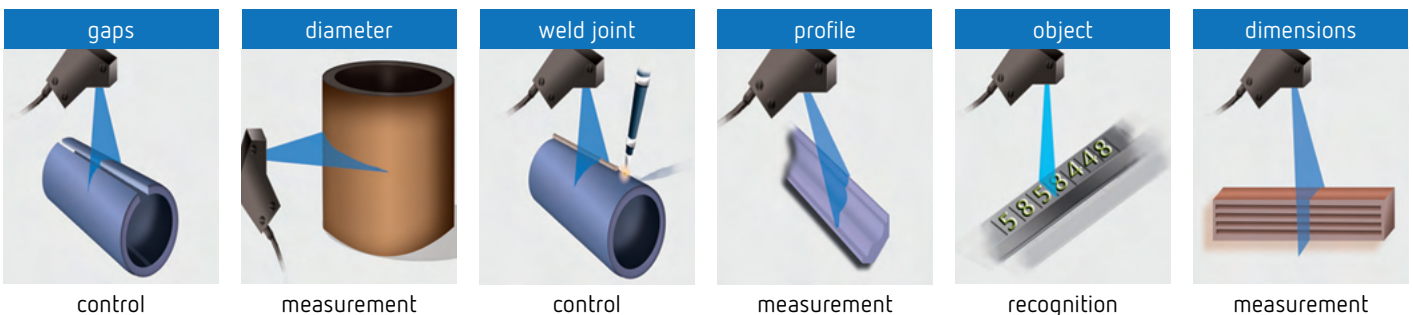

2D LASER SCANNERS

WORKING RANGES

Laser Scanners FDRF625 Series. Working ranges and dimensions									
Range	MR, mm	SMR, mm	EMR, mm	Xsmr, mm	Xemr, mm	Laser	Size, mm	Weight, g	Housing version
40/5-6/7	5	40	45	6	7	Class 2M	30X88X120	400	Compact
35/10-10/12	10	35	45	10	12				
55/10-10/11	10	55	65	10	11				
30/25-18/26	25	30	55	18	26				
65/25-17/23	25	65	90	17	23				
55/50-27/45	50	55	105	27	45				
90/50-23/35	50	90	140	23	35				
75/95-34/67	95	75	170	34	67				
140/110-43/68	110	140	250	43	68	Class 2M or 3B	50X98X144	500	Standard
125/200-60/130	200	125	325	60	130				
100/250-75/180	250	100	350	75	180				
140/250-70/155	250	140	390	70	155				
90/10-9/10	10	90	100	9	10	Class 2M	49X84X162	1000	Special
240/20-14/16	20	240	260	14	16	Class 2M	50X98X144	1000	
175/250-115/230	250	175	425	115	230	4 W, 808 nm, Class 3B	66X171X235	2000	
165/300-130/240	300	165	465	130	240	Class 2M or 3B	48X106X219	1100	
240/290-200/320	290	240	530	200	320	Class 2M or 3B	50X125X360	3000	
450/650-190/420	650	450	1100	190	420	Class 3B	50X110X300	3000	
425/990-330/960	990	425	1415	330	960	Class 3B	48X198X480	2500	Special
540/1400-340/980	1400	540	1940	340	980	Class 3B	48x210X415	3000	

Overall specifications	
Sampling rate and accuracy	
Nominal sampling rate	248 profiles/s (standard mode), 491 profiles/s (mode of increased frequency)
Maximal sampling rate	1875 profiles/s
Linearity, Z axis	±0.1% of the range
Linearity, X axis	±0.2% of the range
Interface	
Digital	Ethernet IPv4
Synchronization inputs/outputs	RS422
Synchronization inputs	up to 3 channels
Synchronization outputs	up to 2 channels
Power supply	15...30 V
Laser lifetime	
Red (660 nm)	50000 hours
Blue (405, 450 nm)	50000 hours
Infrared (880 nm)	50000 hours

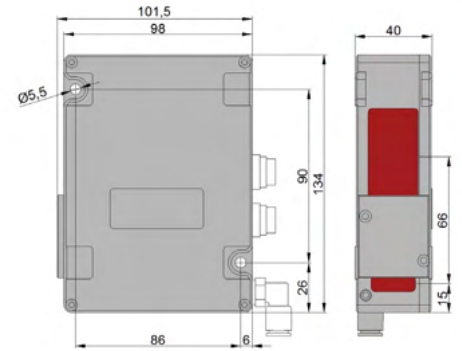

STANDARD VERSION FDRF625

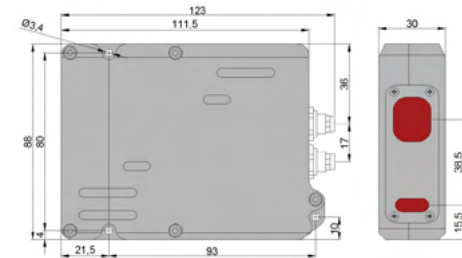

COMPACT VERSION

mm SPECIAL CUSTOM LASER SCANNERS



Rail profile control scanners with high-power (2W) IR laser

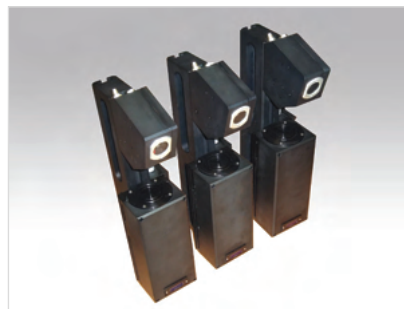

Ore volume control scanners with high-power (2W) IR laser



Internal thread control scanners

SOFTWARE

MAIN FEATURES

- Setting sensor parameters
- Data receiving, storage, visualization
- Custom development possible

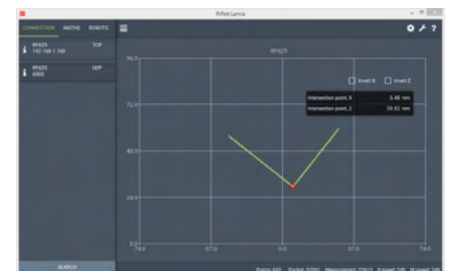

LAMIA IS APPLICATION SOFTWARE FOR CONTROL OF WELDING AND MEASUREMENT ROBOTS, EQUIPPED WITH A **FDRF625** LASER SCANNER.

MAIN FUNCTIONALITY

- Recognizing, tracking and measuring geometric parameters of objects (for example, weld seams) in accordance with the selected math algorithm (template)
- Connecting to the client controllers to transmit results
- Visualizing data
- Setting and control of 2D laser scanner parameters

HOW IT WORKS

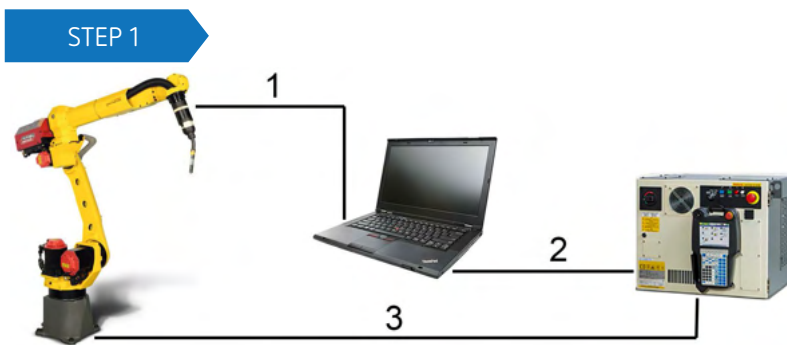

Connect equipment in accordance with functional diagram:

1. Connection between the scanner and the PC with Lamia
2. Connection between the PC with Lamia and the robot controller
3. Connection between the robot and the robot controller

STEP 2

Choose either Measurement Template or Welding Template

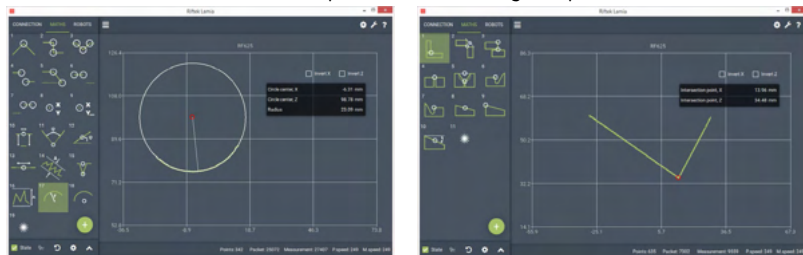

STEP 3

Select Robot Exchange Protocol

ALTHEN P1	R691 USI	ALTHEN P2
Sensor s/n: 206162	Sensor s/n: 206162	Sensor s/n: 206162
Sensor target port: 6003	Sensor target port: 6003	Sensor target port: 6003
Protocol: ALTHEN P1	Protocol: R691 USI	Protocol: ALTHEN P2
Server address: 127.0.0.1	Server port: 5020	Server port: 502
Server port: 502	Timeout, s: 60	Timeout, s: 60
LOCK SENSOR	<input type="checkbox"/> Debug log	CALIBRATION
<input type="checkbox"/> State	LOCK SENSOR	LOCK SENSOR
	<input type="checkbox"/> State	<input type="checkbox"/> State

MAIN FEATURES

- Two sets of ready-to-use math algorithms ("Welding" and "Measurement") for recognizing, tracking and measuring geometric parameters of objects in the realtime mode
- Built-in application ("Template Creator") that allows the users to create their own templates for unique solutions
- Automatic recognition of the objects to measure in accordance with the selected template. There is no need to set the measurement area manually
- Noise reduction: intellectual filtering of the side objects
- Implementation of various protocols for communication with industrial robots
- Calibration of the scanner in accordance with the robot arm
- Work with the scanners of various measurement ranges

STEP 4

START WORKING

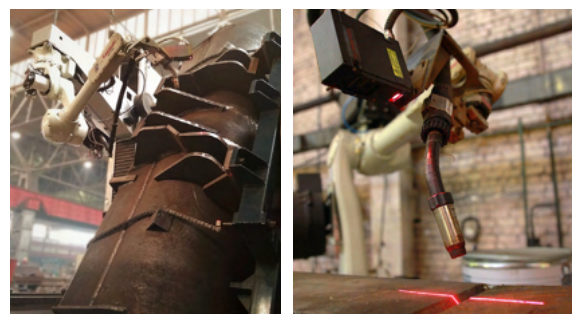

A 3D LASER SCANNING KIT SHTRIKH-2 Series

3D Laser Scanning Kit is designed for mounting on any type of CNC machine and intended for non-contact scanning of products and obtaining 3D computer-simulated models.

In the scanning mode, the machine CNC system moves the sensor line-by-line over the item prototype. Thus, XYZ coordinate array for the surface is formed, i.e. a digital prototype model is created which is saved as a point cloud file as well as in a com-mon STL format suitable for subsequent use in CNC.

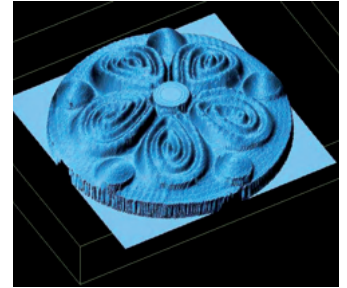
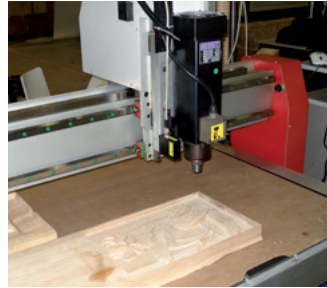

Parameter	Value
Materials to be scanned	any material
Size of scanning area	arbitrary
Average scanning speed, points /s	up to 100 000

A 3D LASER MEASUREMENT MACHINE FDRF1010SS

3D measuring machine is designed for non-contact measurement of geometrical parameters of objects, specifically sunflower seeds. Laser scanner FDRF625 Series, that is installed in the machine, scans the objects and identifies it's geometry. As result of scanning we get the parameters of every sunflower seed and their total quantity.

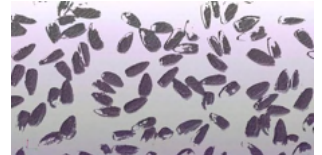

Parameter	Value
Nominal sampling rate, profiles/sec	250
Scanning speed, mm/s	100
Accuracy, um	±150

A 3D LASER MEASUREMENT MACHINE FDRF1010SL

3D Measurement Machine was specially developed to measure suspension arm's parameters for automotive industry. Laser scanner FDRF625 Series, which is installed in the machine, scans the suspension arm, measures and controls its geometrical parameters.

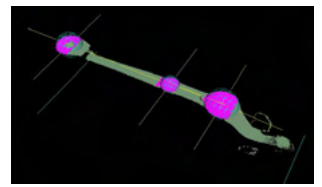

Parameter	Value
Nominal sampling rate, profiles/sec	250
Scanning speed, mm/s	50
Accuracy, % of the range	±0,1

A 3D LASER MEASUREMENT MACHINE FDRF3030BD Series

Specialized measurement machine is designed to control geometric parameters of brake discs and wheel hubs during their production. The system of mobile laser scanners FDRF625 and FDRF603 sensors installed in the machine allows to obtain a computer 3D model of a part and calculate the parameters of run-outs, alignment and cylindricity.

Parameter	Value
Accuracy, mm	±0,005...0,05

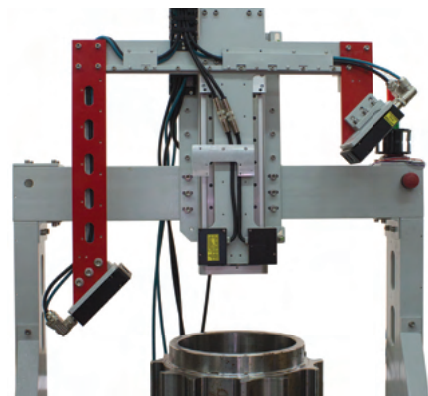

3D LASER SCANNING SYSTEMS

A 3D LASER SYSTEM FOR LARGE DIAMETER PIPES MEASUREMENT FDRF143

The system is designed for non-contact measurement of geometrical parameters (diameter, roundness, curvature) of large diameter pipes. Technical characteristics of the system can be changed for a specific task.

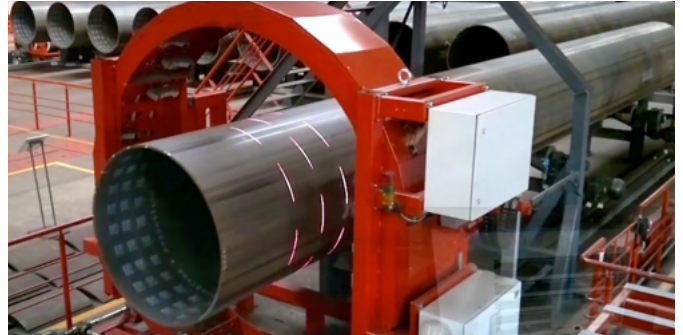

OPERATIONS

The work of the system is based on the principle of 3D laser scanning of object/ objects with subsequent construction of a 3D computer model and determination of geometrical parameters from the model.

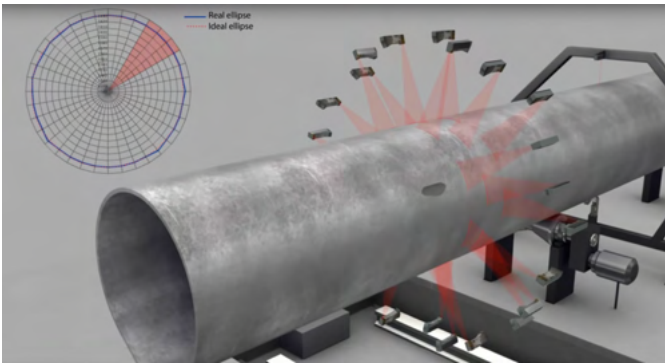

24 pcs of special RFMR625 laser scanners are placed around the moving pipe let to get full 3D model and calculate diameter and roundness.

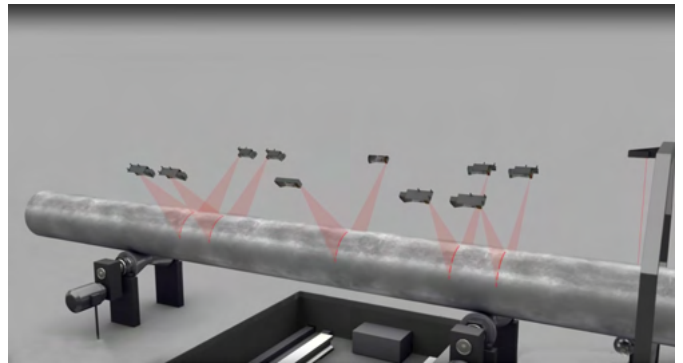

10 pcs of special RFMR625 laser scanners are placed along the moving pipe let to calculate pipe curvature.

SPECIFICATIONS

Parameter	Value
Type of measurement	Diameter, roundness, curvature of the pipe, length of the pipe.
Number of measurement points of the pipe profile (in transverse section)	Up to 24,000 (the entire pipe profile is to be measured using 2D laser scanners), number of scanners: 24.
Method of measurement • Profile	Laser triangulation
Measurements frequency • Diameter, roundness • Pipe profile	Up to 250 Hz
Measurement accuracy • Outer diameter • Inside diameter • Total straightness (pipe warping) • Deviation from pipe ends straightness on basis of 1 m • Pipe ends roundness • Pipe body roundness • Bevel angle • Thickness of the pipe wall • Pipe cutting edge • Bevel dulling • Welded edges displacement • Deviation from theoretical girth • Weld height • Weld width	Not worse than $\pm 0,15$ mm Not worse than $\pm 0,15$ mm Not worse than ± 1 mm Not worse than $\pm 0,1$ mm Not worse than $\pm 0,3$ mm Not worse than $\pm 0,3$ mm Not worse than $\pm 0,3$ mm Not worse than $\pm 0,5^\circ$ Not worse than $\pm 0,1$ mm Not worse than $\pm 0,15$ mm Not worse than $\pm 0,15$ mm Not worse than $\pm 0,1$ mm Not worse than $\pm 0,1$ mm Not worse than $\pm 0,3$ mm
Test speed, m/s	Up to 1,5
Uncontrolled zones in the beginning and end of the pipe at a speed of 1 m/s • Diameter, roundness	Not more than 10 mm



A MULTISENSOR MEASUREMENT HEAD FDRF040 Series

The Multisensor Measurement Module contains up to 6 laser triangulation sensors located circumferentially in one housing at known fixed angles.

The measurement module is inserted into the pipe and moved by translation module to the definite position.

Calibrated laser sensors measure distances to the inner surface .

Software calculates diameter of the pipe.

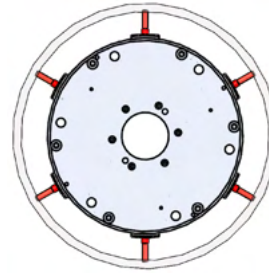

Systems are intended for contactless measuring of inner diameter and profiles of gun barrels, cylindrical and taper pipes, progressive cavity stators, turbodrills and so on.

TWO WORKING PRINCIPLES

- Multisensor measurement by stationary laser sensors - **FDRF040 Series**
- Inner surface laser scanning by rotating sensors - **FDRF096 Series**

SYSTEMS PARAMETERS

- Measured ID – from 6 mm
- Up to several um accuracy
- Up to 32000 measured points on the surface in 2 seconds
- Calculation of ovality and roundness
- Surface defects detection and measurement
- 3D model of inner surface design

SYSTEM STRUCTURE

- Laser measurement module with
 - stationary sensors
 - rotating sensors
- Translation module intended for transportation of measurement module inside the pipe:
 - self propelled
 - any kind of pulling machine
- Software for PC
- Calibration rings

SYSTEM CAN CONTAIN

Centering frame to hold measurement module near pipe axis

OPTIONS

- Pipe straightness measurement module
- Video inspection module
- Wireless connection (Wi-Fi) module

A INNER DIAMETER CONTROL HEAD FOR SMOOTH GUN BARRELS

Parameter	Value
6 laser triangulation sensors	
Diameter range, mm	65...115 or by request
Accuracy, % of range	±0,1



A PIPE DIAMETER CONTROL FOR NUCLEAR STATION

Parameter	Value
Diameter of the module, mm	70
Diameter range, mm	95...195 mm (main range) 160...300 mm (extended range)
Accuracy, mm	0,05 mm (main range) 0,2 mm (extended range)



A 3D LASER SYSTEM FOR CONTROL OF LARGE INNER DIAMETER FIBERGLASS PIPES

Parameter	Value
6 laser triangulation sensors	
Diameter range, mm	500-1250
Accuracy, mm	±0,2



INNER DIAMETER MEASUREMENT SYSTEMS

A ROTATING SENSOR MEASUREMENT HEAD FDRF096 Series

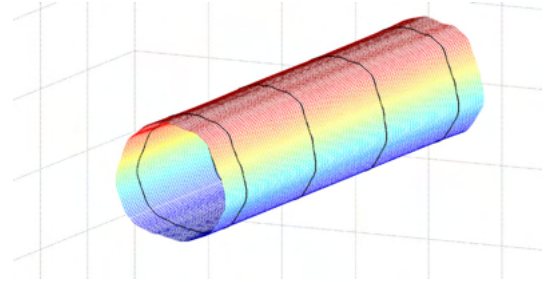
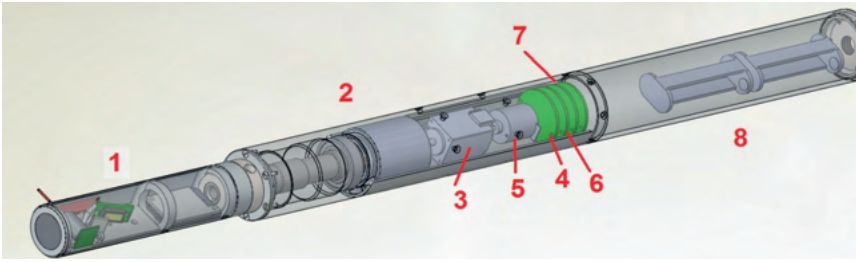

MULTISENSOR MEASUREMENT MODULE CONTAINS

Laser triangulation sensor 1. (one or several with different measurement range and stand-off distance), mounted on rotating platform 2, which contains motor 3 with electronic driver 4, and rotary encoder 5 coupled to the motor 3. The system also includes a tilt sensor 6, intended for control of inclination of rotating platform during measurement.

OPTIONS

In-built Wi-Fi module 7 is used for communication between the system and PC; the system can be powered from internal batteries 8. 2D laser scanner can be installed instead of points sensor.

The measurement module is inserted into the pipe and moved by pulling machine to the definite position. Rotating laser sensor scans inner surface of the pipe and the module transmits polar coordinates of the surface (distance from rotation axis, measured by triangulation sensor and a corresponding angle, measured by encoder).

Software uses the set of transmitted coordinates

- to calculate:
 - ID of measured pipe
 - ovality and roundness
- to find:
 - surface defects
- to design
 - Full profile in definite section
 - 3D model of the pipe inner surface

A WHEEL CENTER BORE INNER DIAMETER MEASURING GAUGE FDRF096-50/70-200

Non-contact scanning and inner surface geometry measurement of wheel center bore.

Parameter	Value
Rotating measurement head with 2 sensors	
ID range, mm	50...70
ID measurement accuracy, μm	± 5
Depth of measurement, mm	200
Autocalibration	



A MOBILE LASER SCANNING SYSTEM FOR PIPE DIAMETER CONTROL

- Rotating measurement head with 2 sensors
- Linear scanning along the tube

Parameter	Value
ID range, mm	146...176
ID measurement accuracy, μm	± 10
Depth of measurement, mm	70
Battery power supply	
Built-in Wi-Fi module	

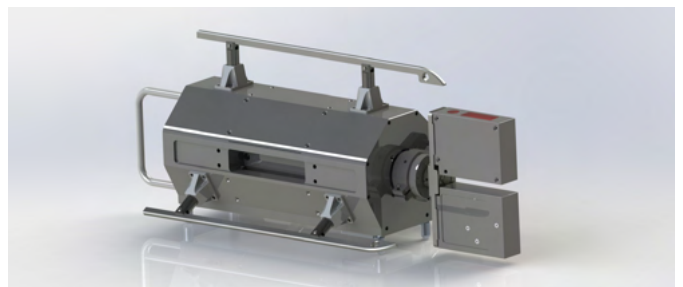

LASER SCANNING SYSTEMS FOR PIPE DIAMETER CONTROL



Parameter	Value
ID range, mm	45...55 or by request
ID measurement accuracy, μm	± 2

INNER DIAMETER MEASUREMENT SYSTEMS

A PIPE INNER DIAMETER MEASUREMENT MACHINE FDRF096 Series

The machine is designed for contactless scanning and geometrical parameters measurement of inner diameter of pipes, bushes, holes, tubes, and so on.

Application of the machine - large-scale production.

Parameter	Value
Measured diameters, mm	32..42
ID measurement accuracy, μm	± 5
Depth of measured hole, mm	≤ 80
Measurement cycle (5 sections), s	13

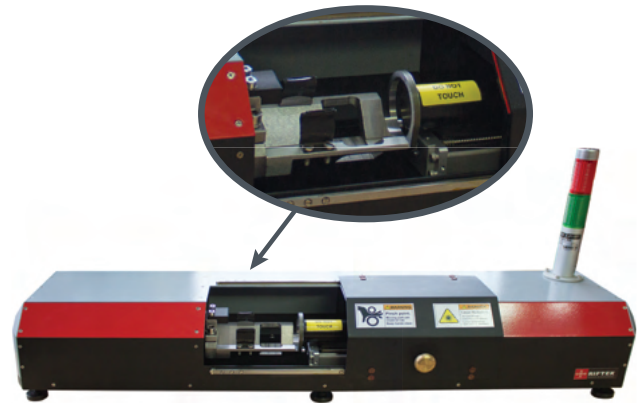

A LEAF SPRING HOLE INNER DIAMETER MEASUREMENT MACHINE

The machine is designed for contactless scanning and geometrical parameters measurement of the leaf springs holes.

Parameter	Value
Measured diameters, mm	30-75
ID measurement accuracy, mm	$\pm 0,04$
Depth of measured hole, mm	120
Measured parameters	diameter, roundness, conicity, cylindricity

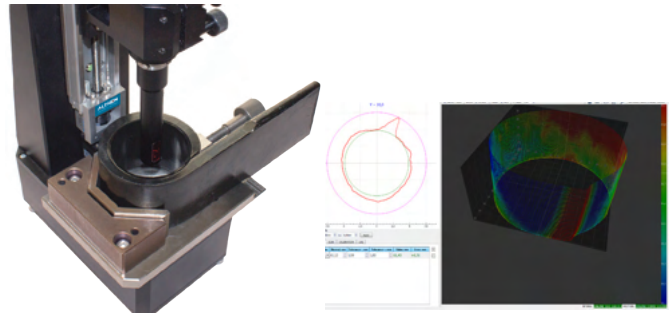

A LASER DEBRIS INSPECTION SYSTEM

The system is intended for non-contact detection of the debris inside the circular grooves of different technological items, for example brake calipers and so on.

The system can be used also for groove seal profiling (seal deformation inspection).

Parameter	Value
Inspected grooves diameter range, mm	35-53
Minimal size of detected debris, mm	0,1X0,1X0,1
Laser sensor linearity, μm	± 10
Depth of measured hole, mm	120
Inspection time, s	1,2

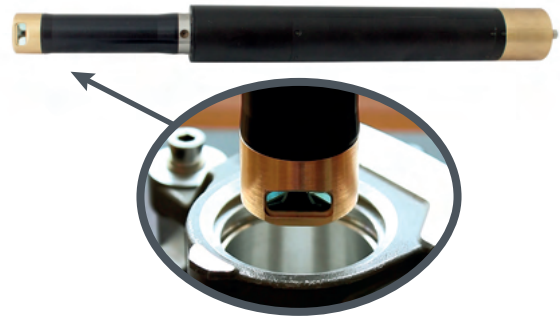

A LASER SCANNING SYSTEM FOR METALLURGICAL NOZZLE INNER DIAMETER CONTROL

- 2D rotating laser scanner
- synchronous linear translation
- air cooling system

Parameter	Value
Measured diameters, mm	50...140
ID measurement accuracy, mm	± 50
Minimum size of defects controlled, mm	0,1



A LAMINATED TUBES GEOMETRY MEASUREMENT SYSTEM

The system is designed for contactless scanning and geometrical parameters (outer and inner diameter, foil thickness, weld width, tube length) measurement of laminated tubes, made of PBL and ABL foil

Parameter	Value
Measured diameters, mm	13..50
Diameter measurement accuracy, μm	± 10
Foil thickness range, mm	0,05..0,5
Foil and weld thickness measurement accuracy, μm	± 5
Tube length measurement accuracy, mm	$\pm 0,1$
Interface to PC	Ethernet
Power supply	220

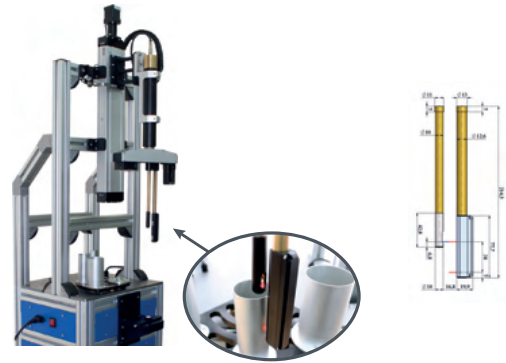

★ APPLICATION LASER SYSTEMS FOR SHEET MATERIALS THICKNESS CONTROL

The systems are intended for in-process contactless measurements of thickness of various sheet materials (plastic, metal, rubber).

ADVANTAGES

- Manufacturing process optimization
- Continuous quality monitoring

OPTIONS

- Based on laser triangulation sensors
- Based on laser scanners
- Based on optical micrometers
- Based on laser absolute linear sensors

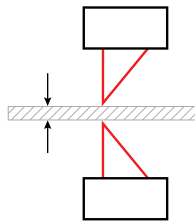

A ONLINE SYSTEMS FOR CONTROL AND REGULATION OF DIAMETER

The systems are designed for non-contact measurement, control and regulation of diameter of technological objects (wire, fiber, hoses, tubes, rods, sausage casings) during their production.

Parameter	Value
Measured diameters, mm	0,3..100
Accuracy, μm	± 1
Number controlled sections	6



A AUTOMATED SYSTEM FOR MOTOR SHAFTS MEASUREMENT

The system is designed for motor shafts measurement and control.

Parameter	Value
Measured diameters, mm	0,1..25
Accuracy, μm	± 1
Carriage movement range, mm	200
Scanning speed, mm/s	50

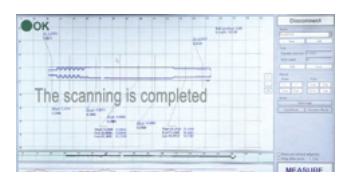
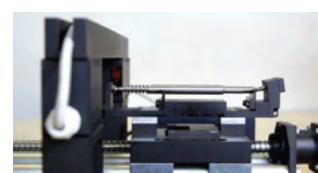



RAILWAY WHEEL PROFILE GAUGE FDKP Series

The laser profilometer is designed for measuring

- Flange thickness, slope and height, rim/tire thickness,
- Full profile scanning and analyze of wheel rolling surface,
- Maintaining of electronic wear data base,
- Control of tolerances and sorting in the course of checkup, examination, repair and formation of railway wheel sets.

The device is supplied with database and software package for wheel sets wear data storage and processing. Measurements are made directly on rolling stock without wheel set roll-out.

PDA is intended for control of the laser scanning module, data reception from the scanning module, indication of measurement result, parameter input and data storage.

Operator mounts the laser scanning module onto the wheel to be measured. Having received a command from PDA or PC, the laser module performs non-contact scanning of the wheel surface.



Parameter	Value
Measurement range flange height, mm	20...45
flange thickness, mm	20...50
flange slope, mm	1...15
rim thickness, mm	36...100 (30...90)
diameter (calculation method), mm	400...1400
Measurement error flange height, mm	± 0,05
flange thickness, mm	± 0,05
flange slope, mm	± 0,1
rim thickness, mm	± 0,1
diameter, mm	± 0,1
Discreteness of indication all parameters, mm	0,01
Profile measurement range, mm	145
Discreteness of the profile formation, not worse than, mm	0,025 (5800 points for profile)
Measurement time, s	adaptive, depending on surface quality, 4 average
Power supply (laser scanning module)	3,7V, Li-ion rechargeable battery 5400mAh for standard IKP and 2400mAh for Short and SShort
The number of measurements that can be taken before battery recharge is not less than	5000
Laser module battery life time	5 million measurement cycles
Power supply (PDA)	3,7V Li-polymer battery 3300mAh
PDA memory capacity	100 000 measurements
Interface between laser scanning module and PDA	Bluetooth
Working temperature range, °C	-30...+50
Enclosure rating	IP42 or IP62



FDKP SOFTWARE

MAIN FEATURES

- User-Friendly Interface, ready for android tablets
- Flexible setting of measured Parameters of the Wheel Flange
- The list of Calculated Parameters:
 - Flange Height, Thickness and Slope
 - Wear parameters (Vertical, Horizontal and Angular Wear, Hollow, Difference of Diameters, Even/Uneven Wear)
 - Angular Profile Parameters
 - Rim Width and Thickness
 - Wheel Diameter
 - Wheel Defects (Slides and Cavities)
 - Special Flange Parameters of the Tram Wheel and etc.
- Setting of displayed Identification Parameters of the Wheelset. I.e., you can select only required parameters (number, series, operator, mileage, and etc.) for displaying on the screen

- Simple Calibration Procedure: it performs automatically by clicking one button
- The possibility to compare several Saved Profiles
- The possibility to align Measured Profile manually (by buttons) relative to the reference with saving
- Possibility to save several Bluetooth-devices in the PDA memory and then to select the required one from the list. I.e. You save addresses of several IKP and after that you need only to select the required one from the list without a necessity of searching procedure (the same is for IMR and IDK)
- Possibility to connect PDA to PC as an External Storage Device (alternative of ActiveSync)



RAILWAY MEASUREMENT INSTRUMENTS

A WHEEL DIAMETER MEASUREMENT GAUGE FDK Series



Electronic gauge is designed for measuring wheel rolling circle diameter. Measurements are made directly on rolling stock without wheel set roll-out. The measurement of the diameter is performed according to the "three points" technique, without the complete wheel coverage. The gauge contains numeric display to show the value of the wheel diameter. IDK-BT gauge contains Bluetooth interface for transfer results into wheel-set wear database management system.

Parameter	Value
Measurement range, mm	400...1400 or on request
Measurement error, mm	±0.2
Indication discreteness	0.1mm, 0.01mm * or 0.01 inch **
Position of measurement, S, mm	On request
Distance between axes of ball bearings (base), mm and diameters measurement range, mm	122±0.5 (400...750 mm) or 200±0.5 (400...950 mm) or 250±0.5 (600...1400 mm) or 300±0.5 (720...1400 mm)
Display	build-in, LED
Operating temperature, °C	-15...+55
Power supply	rechargeable battery 2 x AAA 1.2V
Weight, kg	0.5
The number of measurements that can be taken before battery recharge is not less than	1000

A SPECIAL MODELS OF FOR TRAMS AND LIGHTRAIL FDKP-short AND FDK124

NEW

Special models of FDKP and FDK124 are designed especially for measurement of wheels with restricted space for device placement (tramway wheels):

- Laser Wheel Profile Gauge model **FDKP-short** (Fig. A) with a shortened handle
- Laser Wheel Profile Gauge model **FDKP-Super short** (Fig. B) version for Ansaldo Breda low floor trams
- Wheel Diameter Measurement Gauge model **FDK124** (Fig. C) with the measurement base (distance between ball supports) of the gauge 122 mm and diameter measurement range - 400...750 mm



Fig. A

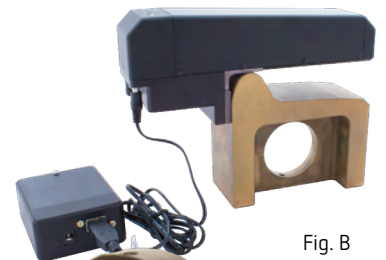

Fig. B

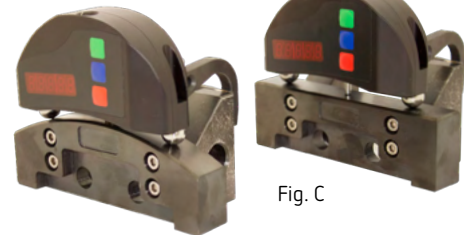
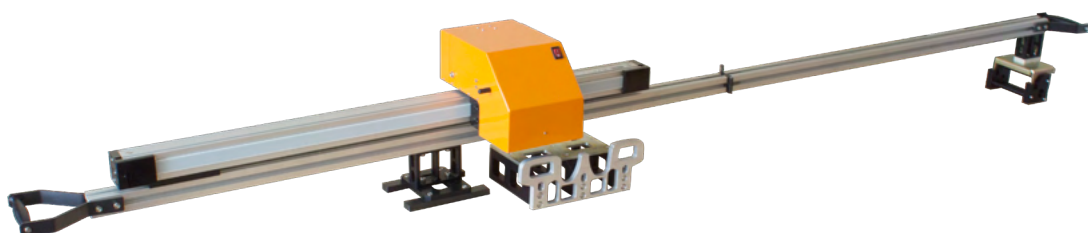

Fig. C

A LASER PROFILOMETER FOR RAILROAD RAILS AND SWITCHERS

The device consists of frame for device placement on the rails and laser measurement head placed with possibility of linear translation. The measurements are carried out automatically. The measurement result is rails transfer profile.

Parameter	Value
Measurement range, mm	600
Measurement error, mm	±0,1



RAILWAY MEASUREMENT INSTRUMENTS

A BACK-TO-BACK DISTANCE MEASURING GAUGES **FDIMR**

Electronic gauge is designed for measuring back-to-back distance of railway, metro and tram wheels in the course of checkup, examination, repair and formation of wheel sets. The method of measurement is based on direct measurement the distance by contactless laser sensor.

Measurements are made directly on rolling stock without wheel set roll-out.

Parameter	Value
Measurement range, mm	L±25 (L – nominal distance)
Measurement error, mm	±0.1
Indication discreteness	0.1mm, or 0.01 inch **
Display	build-in, LED
Operating temperature, °C	-15...+50
Weigh, kg	1
Dimensions, mm	D+137X30X124
Power supply	rechargeable batteries 2xAAA, 1.2V



A BACK-TO-BACK DISTANCE MEASURING GAUGES **FDIMR-L**

NEW

Parameter	Value
Measurement range, mm	1360..1440 or on request (nominal distance ± 15mm)
Measurement error, mm	±0,3
Indication discreteness	0.1mm, 0.01mm * or 0.01 inch
Display	build-in, LED
Operating temperature, °C	-15...+50
Weigh, kg	0,85
Dimensions, mm	234,2x87,7x32
Power supply	rechargeable batteries 4 x AA 1.2V
Connection to PC	Bluetooth

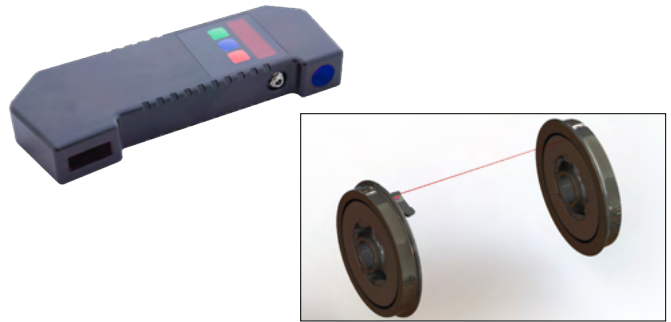

A DISK BRAKES PROFILE GAUGE **IKD Series**

Profilometer uses non-contact method of registration with a laser sensor and a scanning device.

MAIN FUNCTIONALITY

- Obtaining data on the parameters of railway wheel disc brakes working surface
- Full profile scanning and analysis of the working surface of disc brakes
- Visualization of combined graphic images of the actual and new profiles of the wheel brake discs
- Support of the electronic database of profiles

Type 1

IKD-Wheel Mounted
Profilometer for measuring parameters of the disc brakes installed on the wheel.

Type 2

IKD-Axle Mounted
Profilometer for measuring parameters of the disc brakes installed on the wheelset axle.

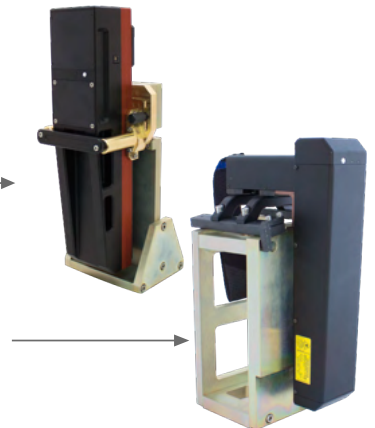

Parameter	Value
Measurement range, mm	30
Profile measurement range, mm	150
Measurement error	± 0,1
Discreteness of indication, mm	0,01
Discreteness of the profile formation, not worse than, mm	0,1
Power supply (laser scanning module Type 1, Type 2)	4,8V, AAA rechargeable batteries, 1,2V
The number of measurements that can be taken before battery recharge is not less than	1000
PDA memory capacity	100 000 measurements
Interface between laser scanning module and PDA	Bluetooth
Working temperature range, °C	-15...+35
Enclosure rating	IP42

RAILWAY MEASUREMENT INSTRUMENTS

A RAIL PROFILE MEASUREMENT GAUGE PRP Series

Portable laser rail profilometer (PRP) is designed for non-contact registration of cross-section of the railhead acting face. The profilometer uses non-contact method of registration with a laser sensor and a scanning device.

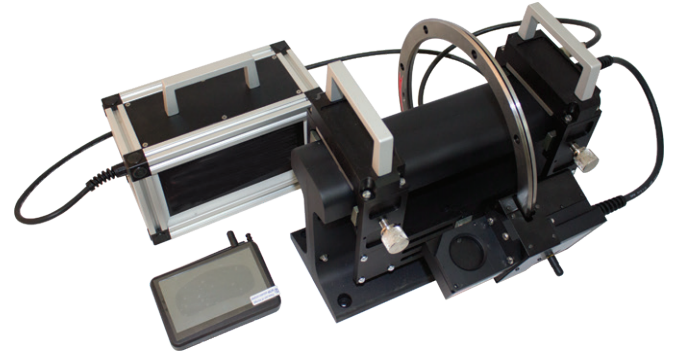

MAIN FUNCTIONALITY

- obtaining the information on the cross-section profile of the working railhead surface
- full profile scanning and analyze of the railhead acting face
- visualization of the combined graphical images of actual and new cross-section

Parameter	Value
Railhead vertical wear, mm	-15,0 ...+20,0
Lateral railhead wear, mm	-15,0 ...+20,0
Reduced railhead wear, mm	Up to 20,0
Scanning angle inside the rail track, degrees	108
Scanning angle outside the rail track, degrees	108
Inaccuracy, not more than, mm	±0.1
Scanning time, sec	3
Power supply, laser module	Lead-Acid battery, 12V, 7200mAh
Power supply, PDA	Lithium-polymer batteries, 3,7V, 3300mAh
The number of measurements that can be taken before battery recharge is not less than	1000
PDA memory capacity, no less	100 000 measurements
Interface to PC	Bluetooth

A RAILWAY DISPLACEMENT MEASUREMENT SYSTEM

MAIN FUNCTIONALITY

- based on FDRF603 laser sensor
- measures vibrations of rails when train passes by
- integrated amplifier and datalogger
- remote controlled measurement



A AUTOMATIC WHEEL MEASUREMENT SYSTEM PRP Series

NEW

The system is intended for contactless automatic real-time measurement of geometrical parameters of railway vehicles (locomotives, railcars, subway, trams) and uses combination of 2D laser scanners mounted wayside in the track area and calibrated into one common coordinate system.

Measurement cycle starts when an inductive sensor detects a wheel. While the wheel passes through the system of synchronized 2D laser scanners its profile is taken at many sections.

All measurement readings for all the wheels are sent through Ethernet to control computer for profiles reconstruction and dimensions calculations.

Finally, all the data are collected in the host depot computer in wheel sets wear database.

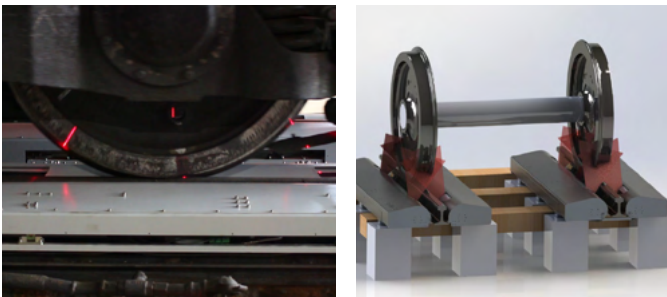

Specifications

- Real-time measurement of moving train wheels
- Easy installing at any type of rail infrastructure
- Incorporating laser scanning technology with different laser wavelength
- Eliminates manual measurement error
- 24 hours operation
- Modular, user-configurable structure
- Double body with conditioning system for outdoor installation

Scope of delivery

- Frames with laser scanners
- Inductive sensors of wheel presence
- Industry computer
- Software
- Calibration frame
- Vehicle (carriage) identification system (Video, RFID)

Basic technical data

Train speed – up to 15 km/hour.

High speed system (up to 150 km/h). Available soon

Parameter	Accuracy
Wheel profiles	± 0,1 mm
Flange height	± 0,1 mm
Flange width	± 0,1 mm
Flange angle	± 0,1 mm
Rim thickness	± 0,1 mm
Tread width	± 0,1 mm
Back to back gauge	± 0,05 mm
Wheel diameter	± 0,2 mm

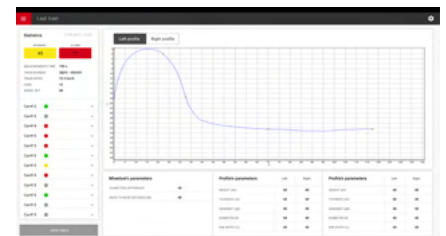
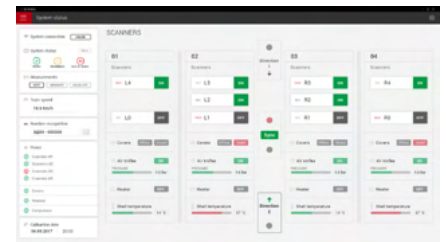
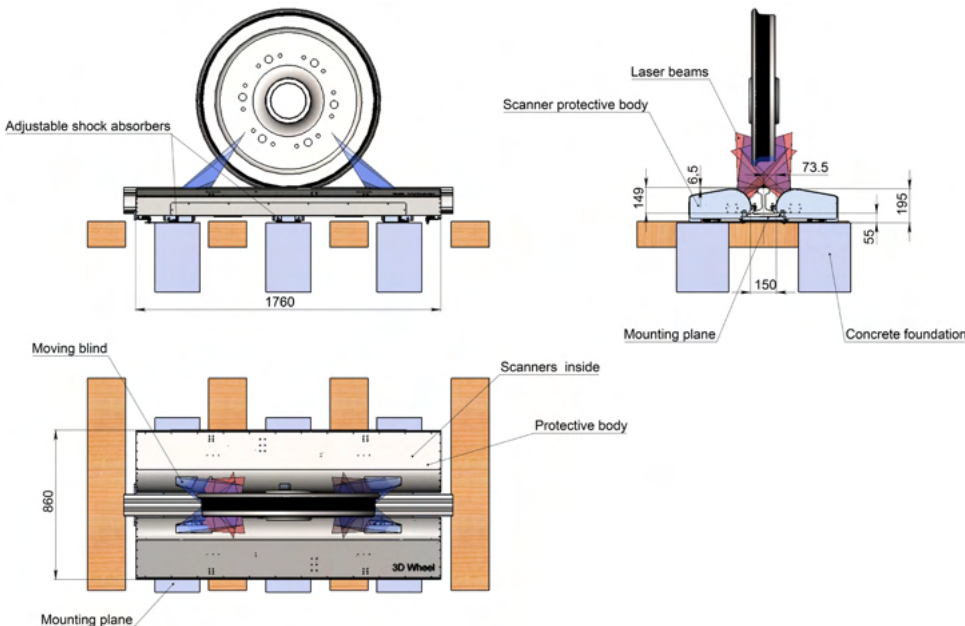

We offer software and hardware solutions for automatic video tracking and object detection for applications in weapons targeting and guidance systems. Create your own effective vision systems on the basis of our products to complete tasks of fire control, weapons

guidance, perimeter control and to achieve high performance of your systems while reducing the development time. Do not limit your choice of computing platforms used in vision system construction.

OUR FOCUS AREAS



PROGRAM LIBs tracking & object detection

Fast tracking & object detection software libraries to be used in processor systems of any type. Also our software libraries can be used in digital signal processors.

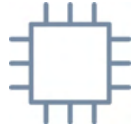

FPGA IP COREs tracking & object detection

Tracking and detection FPGA IP cores to be used in projects involving small-sized energy-efficient systems. Available motion detector & image preprocessing IP cores.

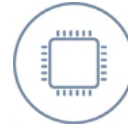

HARDWARE video tracker & object detectors

We develop hardware solutions for tracking & object detection based on various computing platforms. We offer both ready-made solutions and custom ones.

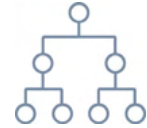

ALGORITHMs tracking, detection & preprocessing

Custom development of video processing algorithms. Solution development based on neural nets for FPGA. Full transfer of rights to the developed algorithms.

VIDEO TRACKING PROGRAM LIB v2.2.1 fast software library for automatic video tracking

MAIN FUNCTIONS

The VIDEO_TRACKER_v2.2.1 software library can make use of any processor platform as a hosting platform. The library is developed in C language (C99 standard) and uses an OpenMP 1.0 parallel computation standard. Compatibility is ensured with any C++ (C) compiler that support the above standards. The software library can be used on x86 processors, ARM, DSP (digital signals processors) and the others given the presence of a compiler that supports C99 and OpenMP 1.0 standard. A variety of computing module standards are available for development engineers, such as COM Express, Compact PCI, PC/104, EXT, XTX, QSeven, etc.



PERFORMANCE

The results (for 128x128 pxl object) for some CPU are shown below:

- i5 - 4590(4 core) - 1.4 ms / 714 fps
- i7 - 4720HQ(8 core) - 1.5 ms / 667 fps
- i3 - 3470(4 core) - 2.9 ms / 344 fps
- Atom-Z8300(4 core) - 10 ms / 100 fps
- Atom-E3950(4 core) - 6 ms / 166 fps
- TI C6678L(8 core) - 15 ms / 66 fps

MAIN CHARACTERISTICS

1. The library can work in systems with one or more automatic tracking channels.
2. Tracking of objects ranging in size from 8x8 to 128x128. The possibility is provided by changing the channel parameters during tracking.
3. Tracking of all types of objects of any shape. There is no tracking collapse if up to 50% of object area changes over no less than 50 frames.
4. Tracking collapse is automatically detected and the object is re-captured after detection.
5. Tracking of dynamic objects. Possible movement of the object by 52 pixels over 1 frame in any direction.
6. Tracking of low-contrast objects against a complex background. Tracking of objects with a contrast from 4%.
7. Calculation of the position and size of object in the tracking rectangle.
8. Adaptation is possible to your conditions of use (changing of operation modes, control logic, algorithm modification).
9. STOP-FRAME mode and compensation of time delays in communication channels during transmission of control commands.

Find out more at www.althensensors.com



VIDEO TRACKING
FPGA IP CORES



MOTION DETECTOR
FPGA IP CORES



C/C++
VIDEO TRACKING
LIBRARIES



C/C++
MOTION DETECTOR
LIBRARIES

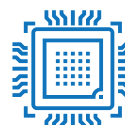

VIDEO PROCESSING
HARDWARE



ALGORITHMS
FOR INDUSTRIAL
APPLICATION



CUSTOM
ALGORITHMS

THE RIGHT SOLUTION FOR YOUR REQUIREMENTS







Thanks to our decades of experience, we at Althen can provide both standard and highly specialized custom sensors as well as complete measurement systems for our customers.

Our product portfolio covers all physical measurements, and we use a wide range of technologies to ensure you always get the best solution for your measurement requirements. Thanks to our vast knowledge, technical expertise, our strong team of engineers from various professional backgrounds, and our broad range of products, we can offer you the most efficient solution for almost any application in every industry.

Our team will be happy to give you advice!

You can call us at +31 (0)70 3 92 44 21 or send an email to sales@althen.nl

OUR PRODUCT SCOPE

bar	Pressure	mm	Displacement	g	Acceleration		Amplifier
N	Force	α	Rotation	m/s²	Vibration		Data Loggers
Nm	Torque		Joystick	°/s	Angular Rate		Automation
ε	Strain		Inclination	°C	Temperature		Measurement Solutions



ALTHEN SENSORS & CONTROLS

■ Netherlands | Belgium | Luxembourg

ALTHEN Sensors & Controls B.V.
 Verrijn Stuartlaan 40
 2288 EL Rijswijk
 Netherlands
 Phone: +31 70 3 92 44 21
 Email: sales@althen.nl

■ Germany | Switzerland | Austria

ALTHEN GmbH Mess- und Sensortechnik
 Dieselstraße 2
 65779 Kelkheim
 Germany
 Phone: +49 6195 7 00 60
 Email: info@althen.de

■ France

ALTHEN / MIDIF
 26, avenue de la Méditerranée
 34110 Frontignan
 France
 Phone: +33 4 67 78 61 66
 Email: info@althensensors.fr

■ USA | Canada

ALTHEN Sensors & Controls Inc
 2340 Littler Lane
 Oceanside CA 92056
 USA
 Phone: +1 858 6 33 35 72
 Email: info@althensensors.com

■ Sweden | Norway | Denmark | Finland

ALTHEN Sensors & Controls AB
 Stora Torget 6C
 761 30 Norrtälje
 Sweden
 Tel: +46 8 7 95 24 90
 E-Mail: info@althensensors.se



Further information can be found at www.althensensors.com