



PCC420V SERIES
RMS and peak velocity loop powered sensors

Wilcoxon’s PCC420V series sensors provide a 4-20 mA output proportional to velocity vibration, allowing for continuous trending of overall machine vibration. This trend data alerts users to changing machine conditions and helps guide maintenance in prioritizing the need for service. The choice of RMS or peak output allows you to choose the sensor that best fits your requirements.



TABLE 1: PCC420VX-YY-C MODEL SELECTION GUIDE

x (4-20 mA output type)	yy (4-20 mA full scale)	C (output connector)
R = RMS output, velocity P = calculated peak output, velocity	05 = 0.5 ips (12.7 mm/sec) 10 = 1.0 ips (25.4 mm/sec) 20 = 2.0 ips (50.8 mm/sec) 30 = 3.0 ips (76.2 mm/sec) 50 = 5.0 ips (127 mm/sec)	R6 = 2 pin, MIL-C-5015 M12 = 4 pin, M12
	10mm = 0.4 ips (10 mm/sec) 20mm = 0.8 ips (20 mm/sec) 25mm = 0.9 ips (25 mm/sec) 50mm = 1.9 ips (50 mm/sec)	

CERTIFICATIONS



Key features

- True RMS or calculated peak output
- Connector options: 2-pin MIL-C-5015 or 4-pin M12
- Compact housing for applications with height restrictions
- Easily integrated into existing process control systems
- Manufactured in an approved ISO 9001 facility

Note: Due to continuous process improvement, specifications are subject to change without notice. This document is cleared for public release.



SPECIFICATIONS

Full scale, 20 mA, ±5%		see Table 1 on page 1
Frequency response:	±10% ±3 dB	10 Hz - 1.0 kHz 3.5 Hz - 2.0 kHz
Repeatability		±2%
Transverse sensitivity, max		5%
Power requirements, 2-wire loop power:		
Voltage at sensor terminals		12 - 30 VDC
Loop resistance¹ at 24 VDC, max		700 Ω
Turn on time, 4-20 mA loop		30 seconds
Grounding		case isolated, internally shielded
Operating temperature range		-40° to +105° C
Vibration limit		250 g peak
Shock limit		2,500 g peak
Sealing		hermetic
Sensing element design		PZT, shear
Weight		120 grams
Case material		316L stainless steel
Mounting		1/4-28 UNF tapped hole
Output connector		2-pin MIL-C-5015 or 4-pin M12
Mating connector		R6 type
Recommended cabling		J9T2A

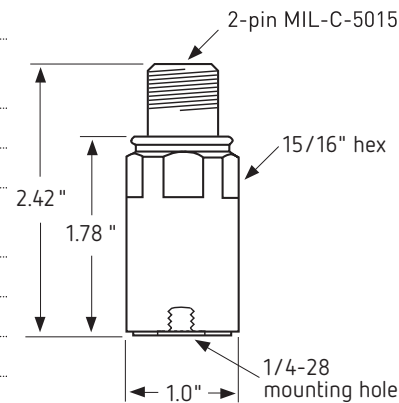

Function	Connector pin
loop positive (+)	A
loop negative (-)	B
ground	shell

Notes: ¹ Maximum loop resistance (R_L) can be calculated by: $R_L = \frac{V_{DC\ power} - 10\ V}{20\ mA}$

DC supply voltage	R_L (max resistance) ²	R_L (minimum wattage capability) ³
12 VDC	100 Ω	1/8 watt
20 VDC	500 Ω	1/4 watt
24 VDC	700 Ω	1/2 watt
26 VDC	800 Ω	1/2 watt
30 VDC	1,000 Ω	1/2 watt

² Lower resistance is allowed, greater than 10 Ω recommended.

³ Minimum R_L wattage determined by: $(0.0004 \times R_L)$.

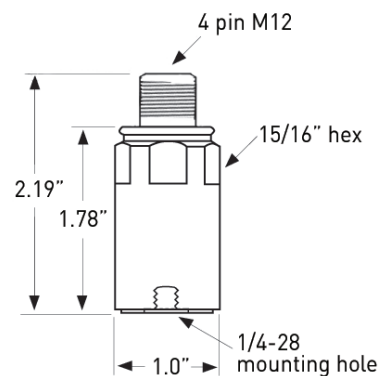

Function	Connector pin
loop positive (+)	1
loop negative (-)	2
N/C	3
N/C	4
ground	shell

Accessories supplied: SF6 mounting stud; calibration data (level 2)

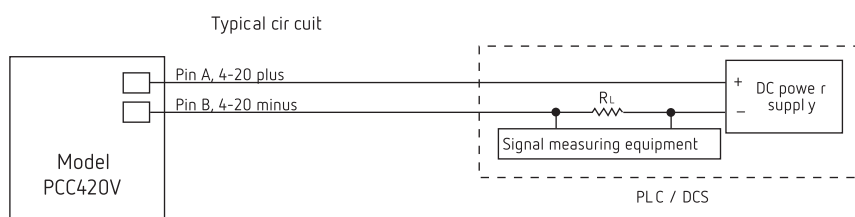

Note: Due to continuous process improvement, specifications are subject to change without notice. This document is cleared for public release.